

EFFECTS OF THE MAJOR MACHINE AND OPERATIONAL
PARAMETERS ON THE PERFORMANCE OF A
MAIZE DEHUSKER - SHELLER

O.C. ADEMOSUN and S.A. ADESUYI
Department of Agricultural Engineering,
Federal University of Technology,
Akure, Nigeria.

ABSTRACT

A lot of drudgery is involved in the manual dehusking and shelling of maize. Therefore, a medium-scale maize dehusker-sheller was developed. The three major machine and operational parameters for the mechanised dehusking and shelling of maize are the clearance between the cylinder spikes (pegs) and the concave, speed of the cylinder and the rate of feeding maize cobs into the machine. The machine was tested based on the effects of the three parameters on the machine to ensure an efficient performance. The effects of the three parameters on the performance of the machine were investigated. The optimum values of the parameters were determined.

Key Words: Maize Dehusker-Shelller, Operational Parameters.

INTRODUCTION

Maize is one of the most important crops in Nigeria. It is produced two times a year in Southern Nigeria by rain-fed farming and throughout the year by irrigation. Dehusking and shelling of maize are tedious and time-consuming. In addition, they are too slow for the high level of production of maize on the farm. It has, therefore, become necessary to mechanise the dehusking and shelling of maize.

Shellers for grains such as wheat and rice are already well developed. Results on the optimum values of the machine and operational parameters are being obtained during tests on the performance evaluation of the machines. While the multicrop thresher of Harrington (1970) was

efficient for mustard, it did not perform well for maize. As discussed in Sharma *et al.* (1984), the axial-flow grain thresher developed by Pathak and Sharma in 1970 was inefficient in the separation of grains from the chopped straw, while the multicrop thresher later developed by Pathak and Sharma in 1979 was found to be efficient only for rice. The tractor-operated multicrop thresher of Sharma *et al.* (1984) was suitable only for wheat and rice. A stationary threshing machine was designed for wheat by Ghaly (1985). The machine was suitable for threshing wheat and chopping the straw. Datt and Annamalia (1991) successfully developed a straight through pegtooth type thresher for rice. The result of the test performed by Chhabra and Singh (1976) with an axial-flow

thresher indicates that a cylinder speed of 700 rpm is required for the threshing of wheat. There was a detailed performance evaluation of the stationary threshing machine for wheat designed by Ghaly (1985). Sharma *et al.* (1984) also evaluated the performance of a tractor-operated multicrop thresher.

Maize is a much larger grain than wheat and rice and it also requires dehusking before shelling. Some efforts have been made by a few local manufacturers in Nigeria to produce maize shellers and to develop maize dehusker-shellers. Such machines include TNAU maize sheller, sherpur maize sheller and Udaipur maize dehusker-sheller. However, results on the performance evaluation of maize dehusker-shellers are still lacking. These results are required in order to achieve an efficient and economical combined maize dehusking-shelling system. The analysis of such results collected under varying crop, machine and operational conditions is required for the establishment of a relationship between crop, machine and operational parameters.

METHODOLOGY

Description of Experimental Equipment:

The experimental equipment designed and fabricated for this study is maize dehusker-sheller. The photograph of the back view of the machine is shown in Fig. 1. The machine consists of a power source, power transmission unit, a hopper, a dehusking-shelling chamber, a blower, a suction fan and grain, cob and light material outlets (Fig. 2).

The power source is a 2.2 KW, 1410 rpm, electric motor. It is the only bought-out component of the machine. Belt and pulley power transmission system is used. As shown in Fig. 2, a 50 mm diameter pulley is mounted on the motor shaft. Two pulleys are mounted on one end of the cylinder shaft. The diameters of the pulleys are 100 mm and 85 mm. A 40 mm diameter pulley is mounted on each end of the blower shaft. A 50 mm diameter pulley is mounted

on the suction fan shaft. Power is transmitted from the motor to the 100 mm diameter cylinder shaft pulley. Power is transmitted from the cylinder shaft to one blower shaft pulley through the 85 mm diameter cylinder shaft pulley. Power is transmitted from the blower shaft to the suction fan shaft through the other blower shaft pulley. Another 120 mm diameter pulley mounted at the other end of the blower shaft transmits power to the 170 mm suction fan shaft pulley. Based on design results, all the belts used are B type, V belt. Also, the diameters of the cylinder shaft, lower shaft and suction fan shaft are respectively 17 mm, 19 mm and 16 mm.

The hopper is the feeding chute through which maize cobs are fed into the dehusking-shelling chamber. It was made from mild steel sheet, SWG 16. The hopper has an oblique shape with a square cross section such that the dimension of the top is 290 mm by 290 mm and the dimension of the bottom is 200 mm by 200 mm. It is partially covered at the top to prevent loss of grain during operation.

The dehusking-shelling chamber consists of a cylinder and concave. The 670 mm long cylinder was made from a 50 mm diameter mild steel rod. The cylinder has four rows of pegs held spirally on its surface by screwing. The spiral arrangement serves, like an auger conveyor, to achieve a linear motion of the maize from the inlet to the outlet during operation. Such continuous movement serves to prevent blockage of the chamber. The pegs were made from a 12.5 mm diameter mild steel rod. The pegs were threaded so that their lengths can be varied for experimentation. The concave plate was made of galvanised sheet, SWG 16 of dimension 670 mm by 300 mm. It is formed into a semi-circle with 14 mm diameter holes spaced all over its surface. Five linings made from 8 mm diameter mild steel rod were welded on the inside surface of the concave. The cover of the concave is also semi-circular mild steel,

SWG 16. The concave cover has an inlet towards one end of its length to which the bottom of the hopper is welded. The clearance between the cylinder and concave was maintained at 44 mm as in the existing local maize shellers earlier mentioned. During operation, the pegs dehusk the maize while shelling is accomplished by the rubbing of the moving cobs against each other and against the rotating cylinder and the stationary concave linings.

The blower and the suction fan are both of the centrifugal flow type. The air stream produced by the blower is directed at the mixture of grain, small sheath and other tiny particles falling from the concave perforations, thereby separating the clean grains. The suction fan draws out the empty cobs from the concave. Each of the blowers and suction fan has six blades mounted on a shaft inside a volute casing. The blades and volute casings were made from mild steel sheet, SWG 16 and the fan blade supports were made from mild steel flat bars of dimension 20 mm by 8 mm.

There are three outlets. All the outlets are made from mild steel sheet, SWG 18. The grain outlet is below the machine, the light material outlet is in front of the machine and the cob outlet is by the side of the suction fan on top of the machine.

Performance Tests

The variety of maize crop used for the performance tests is DMRESR-W. It was obtained from the Teaching and Research Farm of the Federal University of Technology, Akure. The moisture content of the maize was determined by oven dry method and it was found to be 10.8 per cent, wet basis. The maize crop was fully matured.

The three machine and operational parameters varied during the performance tests are the clearance between the cylinder pegs and the concave, speed of cylinder and the rate of feeding maize cobs into the machine. The peg-concave clearance is increased by screwing all the pegs

equally into the cylinder or decreased by unscrewing them equally out of the cylinder. The clearance between each peg and concave is measured with an inside caliper in order to ensure equal peg-concave clearance. The cylinder speed is varied by changing the size of the cylinder shaft pulley to which power is transmitted from the motor. Since the speed of the 50 mm diameter motor shaft pulley is 1410 rpm, the cylinder speed is $\frac{1410 \times 50}{d}$ rpm, where d mm

is the diameter of the cylinder shaft pulley. Therefore, the cylinder speed can be varied from 504 rpm to 1007 rpm by using various cylinder shaft pulleys with diameters of between 140 mm and 70 mm. The rate of feeding maize cobs into the machine is determined by the number of maize cobs manually dropped into the hopper per minute. The feeding rate is accurately controlled with the use of the stop watch.

The procedure for the performance tests is as follows:

- (1) One machine was switched on.
- (2) One maize cob per minute was dropped into the hopper for a period of five minutes.
- (3) The machine was switched off.
- (4) All the materials that were released from each of the three outlets were collected.
- (5) The materials were separated into clean shelled grains, unshelled grains, damaged grains, undehusked cob and sheath.
- (6) Each type of material from each outlet was weighed.
- (7) The top of the concave was removed.
- (8) Any type of material found inside the dehusking-shelling chamber was collected and weighed.
- (9) The efficiency of the machine was evaluated by determining:
 - i) The material discharge efficiency which is the percentage of the total weight of the materials that was released from the dehusking-shelling chamber.
 - ii) The dehusking efficiency which

is the percentage of the percentage of the total weight of cobs that was dehusked.

- iii) The shelling efficiency which is the percentage of the total weight of grains that was shelled.
 - iv) The grain cleaning efficiency which is the percentage of the total weight of materials collected at the clean grain outlet that were grains.
 - v) The percentage of damaged grains which is the percentage of the total weight of grains released from the three outlets that was damaged.
- (10) The dehusking-shelling chamber was cleaned.
 - (11) The top of the concave was re-installed.
 - (12) Steps (1) to (11) were repeated for different feeding rates from one to six maize cobs per minute, without varying the period of feeding of five minutes.
 - (13) Steps (1) to (12) were repeated for different peg-concave clearances from 1.60 cm to 2.60 cm and for different cylinder speeds from 504 rpm to 1007 rpm.

RESULTS AND DISCUSSION

A medium scale maize dehusker-sheller was successfully designed, fabricated and assembled. The machine was in use for about one year before it was used to determine the effects of the major machine and operational parameters on its performance. During the one year, it performed efficiently, well and it never broke down. Initially, there was a slight blockage of the dehusking-shelling chamber. This improper performance was immediately corrected by improving on the spiral arrangement of the pegs on the cylinder.

There were more than 60 rounds of performance tests. It was found that, after any round of performance test, each type of material left in the dehusking-shelling chamber in percentage of the total quantity of each type of material was 0.001 to

0.002 per cent of grains, 0.60 to 0.67 per cent for sheath and 0.008 to 0.009 per cent for cob. Therefore, the spiral arrangement of the cylinder pegs and the suction fan are very efficient in discharging the materials out of the dehusking-shelling chamber.

In any of the performance tests to find out the effects of cylinder peg-concave clearance and the cylinder speed at the various feeding rates, it was found that the percentage of the weight of grains discharged from the light material outlet varied from 0.5 to 1.0 per cent and the percentage of the weight of sheath discharged from the grain outlet varied from 0.7 to 1.5 per cent. Therefore, the performance of the blower is very good.

The effect of cylinder peg-concave clearance on the performance of the machine at various feeding rates is illustrated in Fig. 3. As expected, the quantities of materials discharged from the machine increased with the feeding rate, whereas clearance had no significant effect (Fig. 3a). However, if the clearance is too large, the rubbing action necessary for effective dehusking and shelling is reduced, and the percentage of grain shelled is reduced. Hence, as shown in Fig. 3b, the optimum clearance varies from 1.8 cm to 2.4 cm at a feeding rate of one or two maize cobs per minute, whereas the optimum clearance varies from 2.2 cm to 2.6 cm at a feeding rate of three to six maize cobs per minute. Figure 3b also confirms that, when operating above a clearance of 2.0 cm, the higher the feeding rate, the larger the clearance required. An analysis of the grain damage shows that, in any round of the performance tests, the weights of the damaged grains discharged from the cob outlet and light material outlet vary from 0.0 to 0.4 per cent and from 0.0 to 0.2 per cent respectively. Most of the few damaged grains were discharged from the grain outlet. Generally, at all feeding rates, the percentage of the damaged grains decreases as the clearance increases. As the clearance increases from 1.5 cm to 2.6 cm, the percentage of the damaged grains decreases from 1.6 to 0.0 per cent at a feeding rate

of one maize cob per minute (Fig.3d). The sheath is discharged from the cob outlet and light material outlet. At low clearance, rubbing action is most effective especially when the feeding rate is high and, hence, the sheath is torn into light material and most of the sheath is able to discharge from the light material outlet (Fig. 3e), while the remaining sheath is discharged from the cob outlet (Fig. 3f).

The effect of cylinder speed on the performance of the machine at various feeding rate is illustrated in Fig. 4. Figure 4a confirms that the quantity of grains discharged from the grain outlet increases with the feeding rate. As shown in Fig. 4b, the optimum cylinder speed is between 600 rpm and 700 rpm. While an increase in speed results in a remarkable decrease in the percentage of grains discharged from the grain outlet at low feeding rate, the effect is not much at high feeding rate (Fig. 4b). The reason is that rubbing action per unit time is relatively low at low feeding rate and, hence, sufficient time must be made available for effective rubbing action. Grains are damaged because of the abrasion within grains, and between grains and the cylinder, cylinder pegs or concave. The intensity of such abrasion increases with the speed and the frequency of such abrasion increases with the feeding rate. Therefore, the percentage of damaged grains increases with the cylinder speed and the feeding rate (Fig. 4c).

All the results discussed above were analysed at the optimum cylinder speed of 600 rpm to 700 rpm in order to determine the efficiency of the machine. At a feeding rate of one or two maize cobs per minute when the optimum clearance is between 1.8 cm and 2.4 cm or at a feeding rate of three to six maize cobs per minute when the optimum clearance is between 2.2 cm and 2.6 cm, the material discharge efficiency is between 99.0 per cent and 99.6 per cent, the dehusking efficiency is between 99.0 per cent and 99.7 per cent, the shelling efficiency is

between 97.5 per cent and 98.4 per cent and the grain cleaning efficiency is between 98.7 per cent and 99.6 per cent.

CONCLUSION

A manually fed, medium scale maize dehusker-sheller was successfully developed. The optimum clearance between the cylinder peg and concave is found to be between 1.8 cm and 2.4 cm at a feeding rate of one or two maize cobs per minute and between 2.2 cm and 2.6 cm at a feeding rate of three to six maize cobs per minute. It was also found that the optimum speed of the cylinder is between 600 rpm and 700 rpm, irrespective of the feeding rate. However, higher feeding rate can result in grain damage especially at a cylinder speed higher than 700 rpm. At a normal feeding rate of two maize cobs per minute when the clearance between the cylinder peg and concave is 2.4 cm and the cylinder speed is 700 rpm, the material discharge efficiency is about 99.4 per cent, the dehusking efficiency is about 99.4 per cent, the dehusking efficiency is about 99.5 per cent, the shelling efficiency is about 98.0 per cent and the grain cleaning efficiency is about 99.2 per cent. The capacity of the machine varies from 10 kg to 40 kg of maize cobs per hour, depending on the feeding rate.

ACKNOWLEDGEMENT

The authors are grateful to the Union Bank of Nigeria for their financial support. The assistance of Mr. A. Adesina, Mr. S. Olorunsogo and Mr. A.W. Adewumi during machine fabrication and the assistance of Mr. D.O. Adeyemi and Mr. A. Akinpelu during machine performance tests are acknowledged with thanks.

REFERENCES

- Chhabra, S.C. and Singh, K.N. (1976). Effect of cylinder speed and peg spacing of axial flow thresher on wheat threshing. Journal of Agricultural Engineers, India 14(4): 141-144.

- Datt, P. and Annamalia, S.J. (1991). Design and development of straight through peg tooth type thresher for paddy. Journal of Agricultural Mechanization in Asia, Africa and Latin America. 22(4): 37-42.
- Ghally, A.E. (1985). A stationary threshing machine: Design, construction and performance evaluation. Journal of Agricultural Mechanization in Asia, Africa and Latin America. 16(3); 19-30.
- Harrington, R.E. (1970). Threshing principles confirmed with multi-crop thresher. Journal of Agricultural Engineers, India. 2: 49-61.
- Sharma, V.K.; Ahuja, S.S.; Sandhar, N.S.; Garg, I.K.; Gupta, P.K. and Sandha, J.S. (1984). Design, development and evaluation of a tractor-operated multicrop thresher. Journal of Agricultural Mechanization in Asia, Africa and Latin America 15(4): 26-30.
- Wrubleski, P.D. and Smith, L.G. (1980). Separation characteristics of conventional and non-conventional grain combines. Transactions of American Society of Agricultural Engineers. 23(3): 530-534.

SYMBOLS ON GRAPHICAL ILLUSTRATIONS (Figs. 3 and 4)

- 1, 2, 3, 4, 5, 6: Number of maize cobs fed into the machine per minute.
- W_{gg} : Weight of grains discharged from grain outlet (gm).
- P_{gg} : Percentage of the weight of grains discharged from grain outlet.
- P_{uc} : Percentage of the weight of unshelled grains discharged from the cob outlet.
- P_{dg} : Percentage of the weight of damaged grains discharged from the grain outlet.
- P_{sl} : Percentage of the weight of sheath discharged from the light material outlet.
- P_{sc} : Percentage of the weight of sheath discharged from the cob outlet.

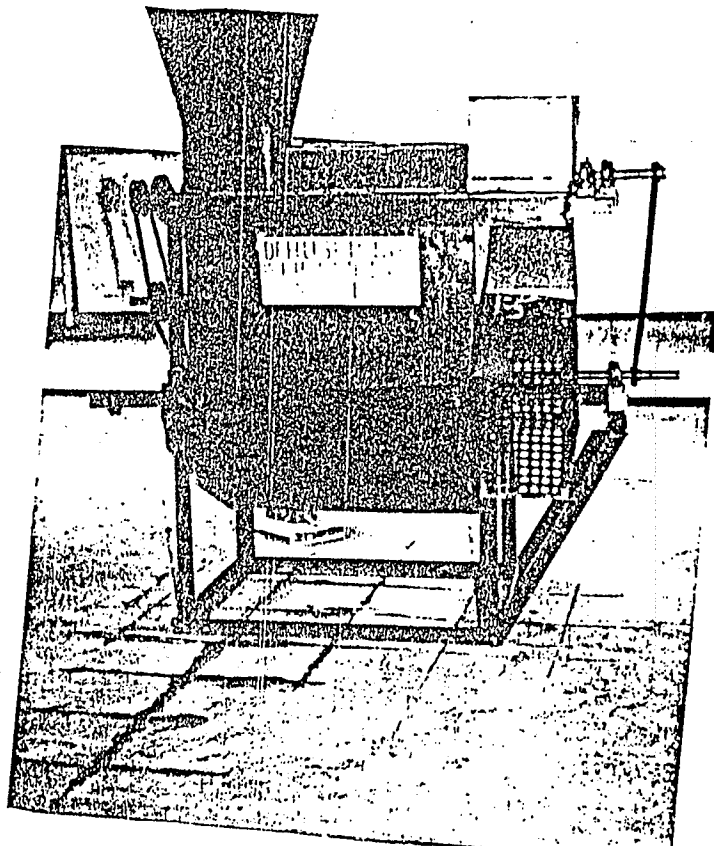

Fig. 1. The back view of the maize dehusker-sheller

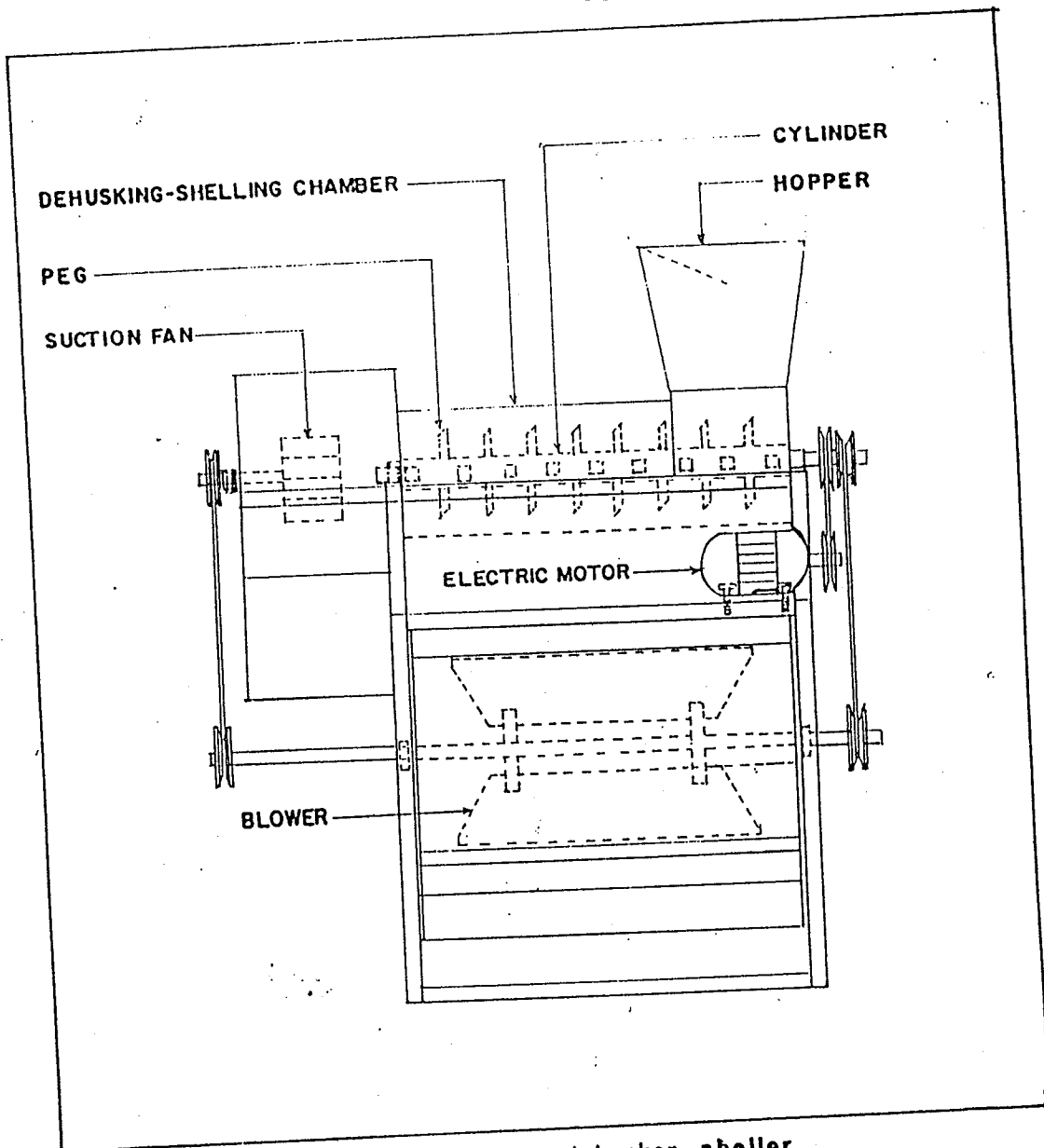

Fig. 2 - The front view of the maize dehusker-sheller.

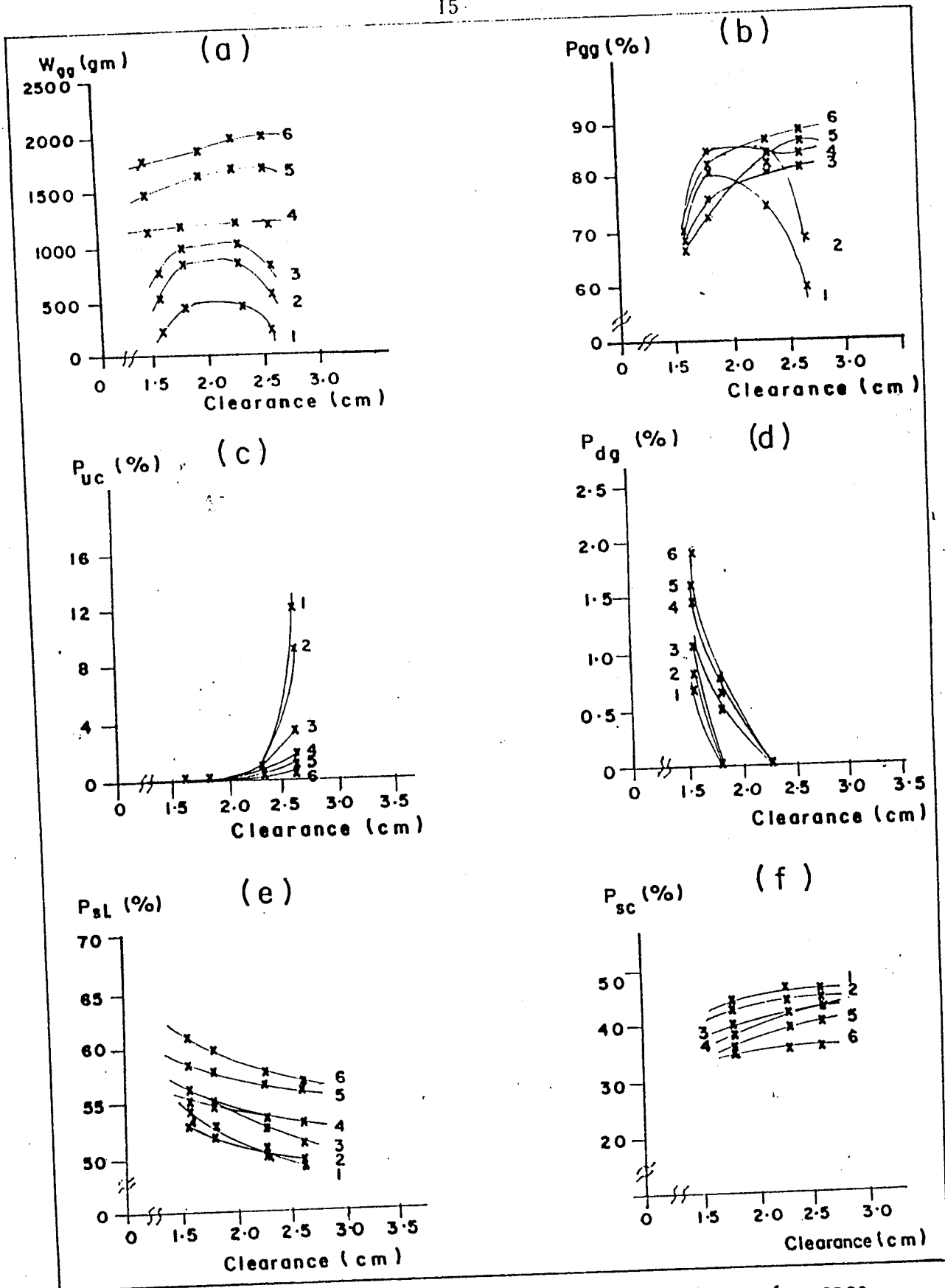

Fig. 3—Effect of cylinder peg — concave clearance on machine performance.

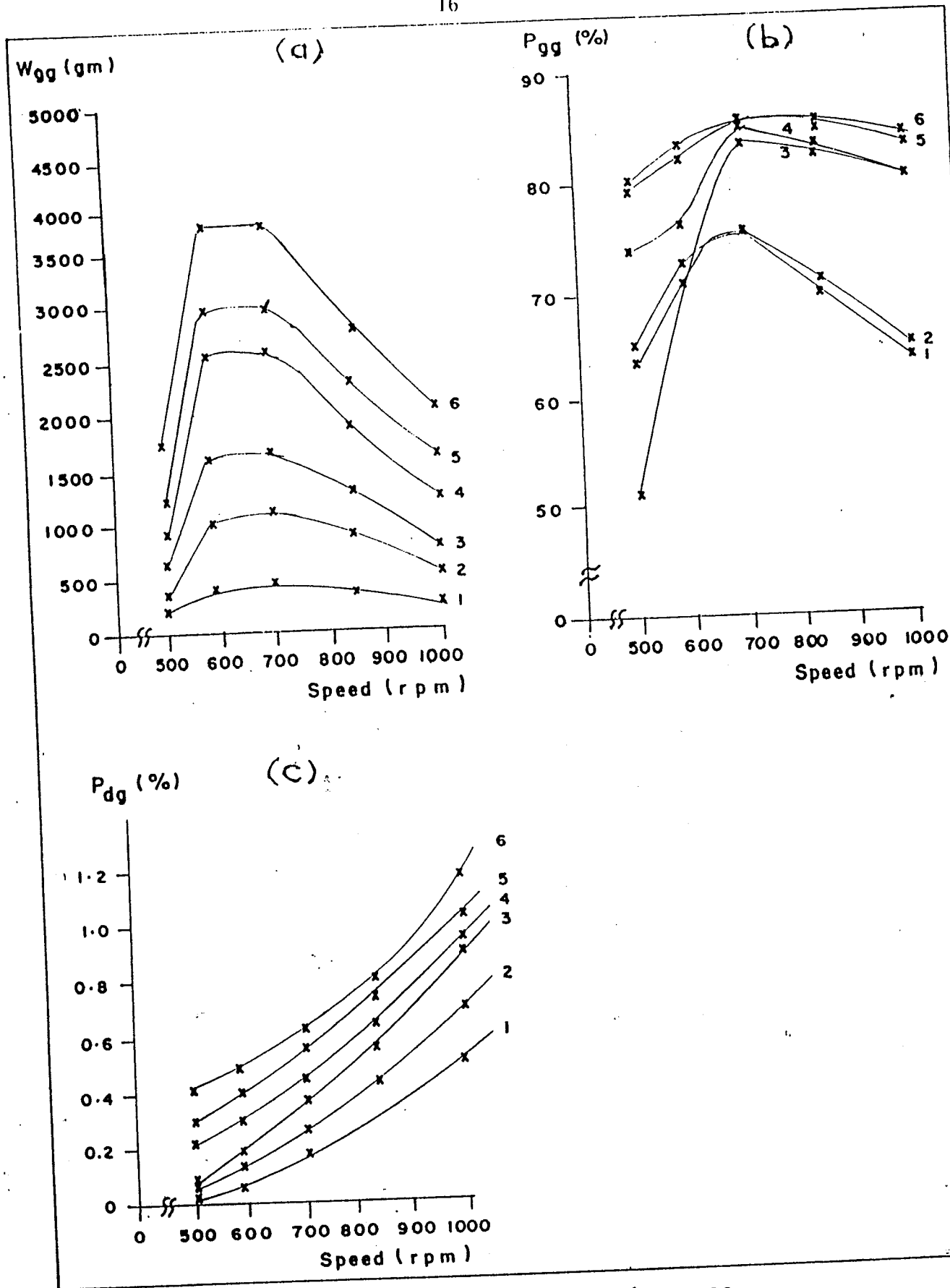

Fig. 4 - Effect of cylinder speed on machine performance.