

Full Length Research Paper

Effect of simulated pulpal pressure on composite bond strength to dentin prepared using Er, Cr: YSGG laser

Siavash Savadi Oskoei, Parnian Alizadeh Oskoei, Soodabeh Kimyai*, Narmin Mohammadi and Sahand Rikhtegaran

Department of Operative Dentistry, Faculty of Dentistry, Tabriz University, Medical Sciences, Tabriz, Iran.

Accepted 21 September, 2009

Bonding to dentin with adhesive systems is affected by the tubular fluid flow induced by pulpal pressure. The aim of this study was to evaluate the effect of simulated pulpal pressure on the microtensile bond strength of an adhesive to dentin surface prepared by laser irradiation. Crowns of twenty human extracted third molars were subjected to Er, Cr: YSGG laser beams. Specimens were divided into two groups according to pulpal pressure simulation. In the first group resin composite (Z-250 Filtek) was bonded to flat surfaces of samples using dentin bonding agent (Single Bond) under simulated pulpal pressure. In the second group, the same procedure was carried out without pulpal pressure simulation. After storing the teeth in saline solution at 37°C for 24 h, thirty 1-mm-thick slices were cut from the samples in each group and subjected to bond strength test. Microtensile bond strength was determined using a universal testing machine at a crosshead speed of 2 mm/min. Statistical significance was determined by T-test ($p < 0.05$). There was a statistically significant difference in the mean microtensile bond strengths between the groups ($p < 0.0005$). Simulated pulpal pressure had a negative effect on microtensile bond strength of laser ablated dentin when Single Bond adhesive system was used.

Key words: Bond strength, laser treatment, pulpal pressure, resin composite.

INTRODUCTION

Adhesive techniques have expanded the range of possibilities for operative and esthetic dentistry (Kato and Nakabayashi, 1998). Bonding to enamel is a relatively simple procedure, without major technical requirements or difficulties. Bonding to dentin represents a much greater challenge, which may lead to clinical failure of restorations if it is not carried out meticulously (Jacques and Hebling, 2005). Dentin is a dynamic tissue with a complex structure. A serum like fluid fills dentinal tubules, which flows from the pulp chamber by hydrodynamic pressure of approximately 24 cm Hg or 32.5 cm H₂O in vital teeth (Ciucchi et al., 1995). Bond strength between resin and dentin is correlated with the degree of resin infiltration into collagen fibers exposed by demineralization of dentin (which is very important in bonding process) and infiltration of resin into dentinal tubules. The

infiltration zone is called hybrid layer (Pioch et al., 2001). Tubular fluid can affect this layer. The water content of this fluid interferes with polymerization of the adhesive, resulting in suboptimal conversion rates (Moll et al., 2005). During cavity preparation with conventional techniques such as bur cutting or hand instrument a smear layer is formed (Tay et al., 2000). This layer is quite effective in reducing hydrostatic pressure (Cardoso et al., 2008). Based on the interaction of adhesive resin and dentin surface two main approaches might be used to classify modern adhesion including: smear layer modifying approach (self-etch bonding systems) and smear layer removing approach (total etch systems). The latter approach is the most effective technique to achieve stable bonding to enamel and dentin (Oliveira et al., 2003). Today there are alternative technologies for cavity preparation and dentin conditioning, such as laser ablation (Mehl et al., 1997). Among several laser types Er, Cr: YSGG (erbium, chromium: yttrium-scandium-gallium-garnet) and Er: YAG (erbium: yttrium-aluminium-garnet) lasers have a potential to remove dental hard tissues and

*Corresponding author. E-mail: kimyais@tbzmed.ac.ir. Tel: 0098411- 3340310. Fax: 0098411-3346977.

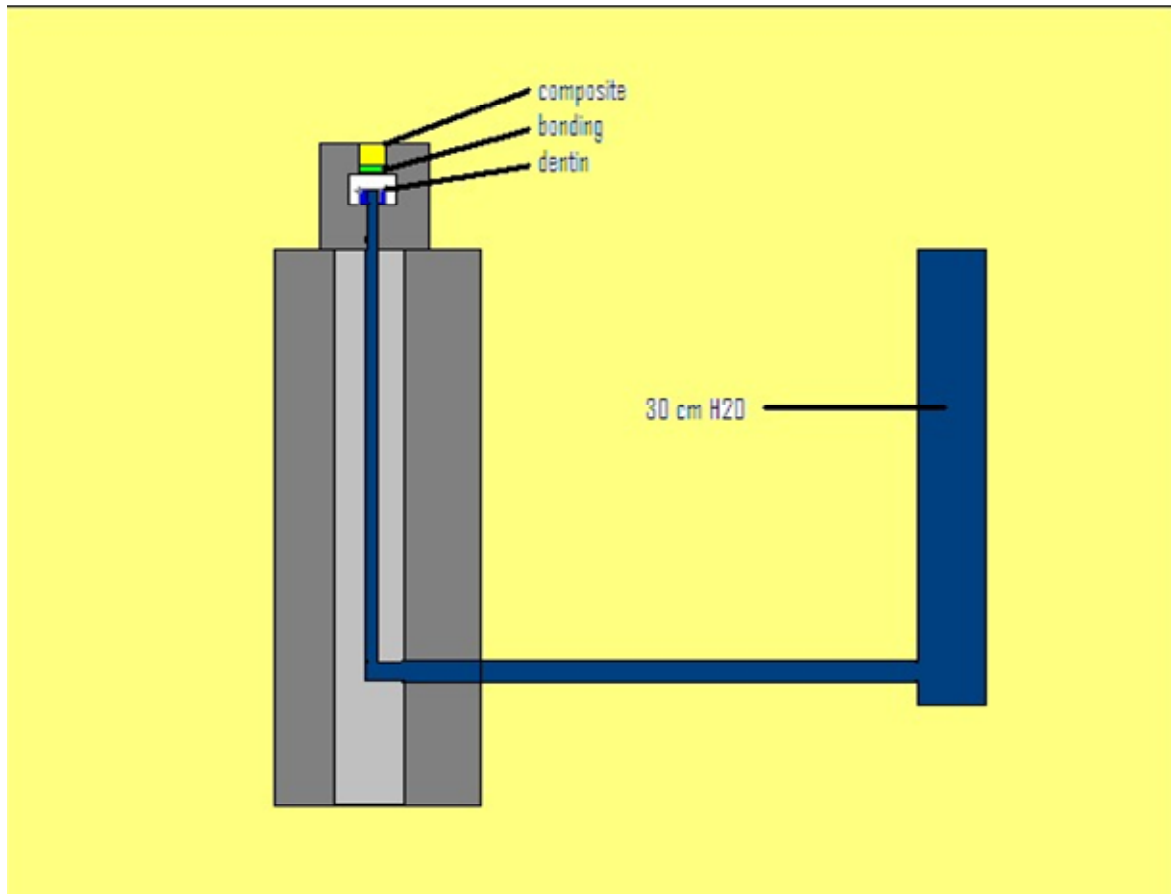

Figure 1. Schematic design of pulpal pressure simulator apparatus.

carries without damaging pulp tissues (De Moor and Delmé, 2006). Laser ablates dentin and leaves a crater-like appearance with opened dentinal tubules and no smear layer; as a result, the tubular fluid effect is more apparent (Stern and Sognnaes, 1965). The tubular fluid flow pressure plays an important role in clinical situations. For instance, vasoconstrictors in local anesthetic solutions have been reported to enable the reduction of intrapulpal pressure in vital teeth and when used prior to dentin bonding enhanced resin bonding should be expected. These reports led to recommendations to test bond strengths under pulpal pressure (Pioch et al., 2001). Simulation of pulpal pressure could be a step to establish the relationship between *in vitro* studies and real clinical performances. The effect of simulated pulpal pressure on Er, Cr: YSGG laser prepared dentin-adhesive bond strength has not been evaluated yet. The aim of the present study was to evaluate the effect of intrapulpal pressure on microtensile bond strength (μ TBS) of composite resin to Er, Cr: YSGG laser prepared dentin.

MATERIALS AND METHODS

Twenty extracted human third molars were selected for this *in vitro*

study. After cleaning debris from the teeth, the samples were stored for no more than one month in 1% Chloramine T Trihydrate (Sigma-Aldrich, Schnelldorf, Germany) at 4°C to prevent bacterial growth. The crowns of the samples were separated from the roots at the CEJ (cemento-enamel junction) using a diamond-coated band saw under continuous water cooling. Dentin thickness between the pulp chamber and the occlusal plateau was adjusted to 1.3 mm (\pm 0.1 mm). The surfaces were finished with a 1000-grit silicon carbide paper. Er, Cr: YSGG dental laser system (Biolase Europe GmbH, Paintweg 10, 92685 Floss, Germany) with 2780 nm wavelength was used with a pulse duration between 140 and 200 μ s and a pulse repetition rate of 20 pulses per second (20 Hz). The samples were ablated by 2 W power and 20% air spray and 15% water spray. A custom-designed apparatus was used to achieve a fixed 1 mm distance between the laser tip and the tooth surface. This apparatus also enabled us to maintain a fixed laser tip movement speed over samples; therefore, all the samples were irradiated in a similar pattern. Irradiation was carried out with a G type laser tip with a 600- μ m diameter. The laser treated-samples were divided into two groups of 10 teeth each using simple random sampling method. Group 1 included teeth for bonding under simulated pulpal pressure. Group 2 included teeth for bonding without simulated pulpal pressure.

In the first group, the specimens were mounted on an experimental apparatus designed for simulating intrapulpal pressure (Figure 1). The pressure was adjusted to 30 cm H₂O. Then all the samples of both groups were etched with 35% phosphoric acid gel (Scotchbond TM Etchant, 3 M ESPE, Dental Products, St. Paul, MN, USA) for 15 s and then rinsed with water for 10 s and dried

Table 1. Mean values and standard deviations (SD) of μ TBS (MPa) in two groups.

Group	N	Mean	SD
Group 1	30	15.30	3.07
Group 2	30	23.69	6.62

with light air flow for 1 - 2 s from a 2-cm distance to achieve a shiny appearance on dentin. In the next step, dentin bonding agent (Adper TM Single Bond 3 M ESPE, Dental Products, St. Paul, MN, USA) was applied in two layers and the samples received an air flow for 2 to 5 s and were cured for 10 s using Astralis 7 light-curing unit (Ivoclar Vivadent, FL-9494 Schaan/ Liechtenstein) with 400 mW/cm² power density. A hybrid composite restorative material, Z-250 Filtek TM (3M ESPE, Dental Products, St. Paul, MN, USA), was applied in 1 mm thickness layers. Each layer was cured with the same light-curing unit for 40 seconds with the same power density on surface area to make a bulk with a height of 4.5 mm. Once the composite block had been built up, each tooth was placed in 37°C saline solution for 24 h in an incubator. Then the samples were secured on an acrylic resin cylinder (Triplex, Ivoclar Vivadent AG, FL-9494 Schaan/ Liechtenstein) with sticky wax. All the samples were vertically sectioned with a low-speed diamond saw through the composite buildups and dentin at 1 mm increments to produce a series of 1-mm thick specimens. A total of 60 slices (30 in each group) were randomly selected (3 slices of each tooth). Then the slices were trimmed to form dumbbells for microtensile bond strength testing. Each dumbbell was bonded to a jig in Hounsfield Test Equipment (Model H5K-S, Tinius Olsen Ltd, Surrey, England) and operated in tension at a crosshead speed of 2 mm/min until failure. Microtensile bond strength was defined as the amount of loading at the peak of load-extension curve. The microtensile bond strength was calculated in Mega Pascal (MPa). Data was analyzed using independent samples T-test at a significance level of 0.05. The percent changes of microtensile bond strength mean values resulting from pulpal pressure simulation were calculated.

RESULTS AND DISCUSSION

The mean values and standard deviations (SD) of the microtensile bond strengths in two groups are presented in Table 1. Independent sample T-test results showed that there was a significant difference in the microtensile bond strength values ($P < 0.0005$). Pulpal pressure simulation resulted in 35.4% reduction of mean bond strength value.

Bonding to laser prepared dentin and bur cut surfaces has different patterns and bond strength values due to subsurface damage caused by Er, Cr: YSGG ablation and vitrification effect, which is seen with excessive laser energy output can affect dentin bonding strength (De Moor and Delmé, 2006). Laser irradiation with a 2 W output power was used in the present study, which may be a standard value for dentin preparation, as mentioned in a previous study to reduce these adverse effects (Delmé et al., 2006). In the present study microtensile bond strength test was used, which offers some advantages compared to conventional shear or tensile tests such as a more homogenous stress distribution during loading and smaller number of cohesive failures in dentin.

The modulus of elasticity of the resin composite has been shown to influence the results of bond strength measurements (Moll et al., 2005). Therefore, the same resin composite material was used in both groups in this study. A bonding agent (Single Bond) with etch and rinse approach was used in this study. All-in-one and self-etch approaches were not advised for laser prepared-dentin bonding while these adhesive systems were not able to remove the damaged superficial layer of dentin and attached melted collagen fibers produced by laser ablation (Martinez-Insua et al., 2000). The amount of pulpal pressure *in vital* teeth is not the same in different clinical and physiological situations. Increases in systemic and local blood pressures due to inflammation or systemic problems may lead to an increase in pulpal pressure. Conversely, decreasing local blood pressure via injection of local anesthetic solutions containing vasoconstrictors may decrease the pulpal pressure (Oliveira et al., 2003). The average value of this pressure has been reported to be about 30 to 40 cm H₂O in normal physiologic conditions (Gupta and Tewari, 2006). As a result of this pressure the increased outward flow of tubular fluid after removal of smear layer has been described to counteract the penetration of resin monomers to dentin surfaces dependent on the type of monomers used. HEMA (2-hydroxyethyl methacrylate) is one of these monomers. The presence of HEMA makes the complete evaporation of water much more difficult, because a rise in HEMA concentration lowers the vapor pressure of water. As a consequence, the residual water may interfere with polymerization of the adhesive monomers. Dilution of primer monomers by the increased outward flow of water after phosphoric acid-etching is an explanation for much more pronounced decrease of bond strength in etch and rinse approach (Moll et al., 2005).

Another influencing factor is the ability of resins to polymerize and crosslink in the presence of water. An inhibitory effect of water on the polymerization of light-cured bonding resins has been reported in a previous study (Moll et al., 2005). When pulpal pressure is induced water droplets are detected on the outer surface of polymerized adhesive film. Most adhesive systems contain a relatively high concentration of solvents and hydrophilic monomers, such as HEMA, to improve wetting and spreading of adhesives on dentin. Such highly hydrophilic co-monomers produce highly hydrophilic polymers that permit movement of water molecules from dentin across the adhesive layer. The *in vitro* application of simulated pulpal pressure obviously increases connective fluid movement and reveals through-and-through water channels in the adhesive. These water filled channels are potential sites of hydrodynamic degradation that may adversely affect the longevity of restorations bonded to dentin after adhesive polymerization (Sauro et al., 2007). On the other hand, hydrophilic components such as HEMA are capable of imbibing large amount of water within the adhesive and hybrid layers. Hence, water remains entrapped at resin-dentin

interfaces. The presence of water within adhesive film may compromise mechanical properties of polymers, such as its tensile bond strength and its modulus of elasticity (Sauro et al., 2007). The results of this study indicated that bonding to laser prepared-dentin surfaces is susceptible to water flow-induced by pulpal pressure. Bonding agent which was used in our study, Single Bond (3M ESPE), contains HEMA so bonding could be affected by the mechanisms explained above. The results of this study were parallel to the results of previous studies in which bond strength to bur cut dentin was decreased via pulpal pressure simulation (Pioch et al., 2001; Moll et al., 2005; Tay et al., 2000; Gupta and Tewari, 2006; Sauro et al., 2007).

Brulat et al. (2008) compared shear bond strength of self etching adhesive systems to dentin prepared by Er: YAG laser, with and without pulpal pressure simulation and they did not find any difference in bond strength to lased dentin due to pulpal pressure (Brulat et al., 2008). The differences between the results of that study and our study may be related to the difference of adhesive systems, bonding surface depth, laser irradiation parameters and patterns of loading in bond strength testing. Conversely, Ozturk et al. (2004) have reported significant increase of bond strength of complete cast crowns under simulated pulpal pressure using an adhesive luting agent (Superbond C&B). They explained that in their study, non-flat surfaces were examined for bond strength and the samples had a marginal seal due to complete cast restorations, which was absent in other studies (Ozturk et al., 2004).

Pioch et al. (2001) compared shear bond strength of different bonding agents with simulated pulpal pressure and without it; they concluded that pulpal pressure simulation decreases bond strength of all bonding agents. Confocal laser scanning microscopy analysis of dentin-adhesive interface revealed a shallower penetration of the adhesives into dentin surface in samples with pulpal pressure (Pioch et al., 2001). Although, the bond strength test method of their study (shear bond strength) was different from our study (microtensile bond strength), the results were similar. Moll et al. (2005) evaluated microtensile bond strength of self-etching adhesive systems with simulated pulpal pressure. The simulated pulpal pressure reduced microtensile bond strength of all the adhesives in their study, whereas this effect was not significant with Clearfil SE-bond (Moll et al., 2005). This was explained by a different etching pattern, filler content (which is 10% filled) and significant higher bond strength of this adhesive to dentin (without pulpal pressure) which makes it less sensitive to fluid flow from pulpal pressure (Moll et al., 2005). Sengun et al. (2005) measured the microtensile bond strength of direct and indirect composite materials to dentin under simulated pulpal pressure on pulpal and remote regions of dentin. They reported that while strength of bonding systems at pulp horn region was decreased, bond strength of dentin surface was less affected according to regional differences (Sengun et al.,

2005). The results of our study are in accordance with this study, while the bonded surfaces of samples of our study consisted of permeable regions of dentin near pulp chamber and were significantly affected by simulated pulpal pressure.

Sauro et al. (2007) compared the microtensile bond strength of self-etching adhesives under and without simulated pulpal pressure. They reported that simulated pulpal pressure significantly reduced bond strength values, but the amount of this reduction was not the same for different bonding agents. The tensile bond strength values of two simplified adhesive systems (One Up Bond F and Clearfil S3-Bond) decreased by 71 - 72% when they were subjected to pulpal pressure. Conversely, although the tensile bond strength of G-bond dropped significantly when pulpal pressure was applied, the reduction percentage was only 32%, which was the smallest reduction percentage in bond strength values produced by the application of pulpal pressure in this study. This was justified by the differences in hydrophilic natures of adhesives monomers, while blisters and water channels of HEMA-based adhesives (with more hydrophilic monomers) were responsible for inducing greater stress at the interface between the adhesive film and overlying resin composite. The only HEMA free adhesive tested (G-bond) had the least reduction in bond strength values due to intrapulpal pressure simulation (Sauro et al., 2007). Considering these results, a great decrease in bond strength due to pulpal pressure simulation must have been expected in our study. However, in our study the bonding agent (Single Bond) had hydrophilic co-monomer (HEMA) in its combination and there was a lack of smear layer due to laser application (resulting in much more fluid flow under simulated pulpal pressure to dentin-adhesive interface), which was expected to give rise to more reduction in bond strength values. Conversely, the decrease of bond strength was only 35.4%, which shows lower values compared to Sauro's study. This might be explained by the effect of polyalkenoic acid copolymers in the Scotchbond products (such as Single Bond), which is incorporated into its structure to reduce its moisture sensitivity and better stability over time. Reversible breaking and reformation of calcium-polyalkenoic acid complexes in the presence of water suggested developing a stress-relaxation capacity without rupture of adhesion at any time (Kato and Nakabayashi, 1998).

Within the limitations of this *in vitro* study, it was concluded that simulation of pulpal pressure could decrease the microtensile bond strength of adhesives to Er, Cr: YSGG prepared dentin. Decreases in bond strength may be affected by many variables, especially bonding agent composition.

ACKNOWLEDGMENT

The authors would like to thank the Vice Chancellor for

research at Tabriz University (Medical Sciences) for the financial support.

REFERENCES

- Brulat N, Leforestier E, Rocca JP, Darquet-Cerretti E, Bertrand MF (2008). Shear bond strength of self-etching adhesive systems to Er:YAG laser-prepared dentine with and without pulpal pressure simulation. *Photomed. Laser. Surg.* 26: 579-583.
- Cardoso MV, Coutinho E, Ermis RB, Poitevin A, Van Landuyt K, De Munck J, Carvalho RC, Van Meerbeek B (2008). Influence of dentin cavity surface finishing on micro-tensile bond strength of adhesives. *Dent. Mater.* 24: 492-501.
- Ciucchi B, Bouillaguet S, Holz J, Pashley D (1995). Dentinal fluid dynamics in human teeth, in vivo. *J. Endod.* 21: 191-194.
- De Moor RJG, Delmé KIM (2006). Erbium lasers and adhesion to tooth structure. *J. Oral. Laser. Appl.* 6: 7-21.
- Delmé KIM, Deman PJ, De Bruyne MAA, De Moor RJG (2006). Influence of different Er:YAG laser energies and frequencies on the surface morphology of dentin and enamel. *J. Oral. Laser. Appl.* 6: 43-52.
- Gupta R, Tewari S (2006). Effect of rotary instrumentation on composite bond strength with simulated pulpal pressure. *Oper. Dent.* 31: 188-196.
- Jacques P, Hebling J (2005). Effect of dentin conditioners on the microtensile bond strength of a conventional and a self-etching primer adhesive system. *Dent. Mater.* 21: 103-109.
- Kato G, Nakabayashi N (1998). The durability of adhesion to phosphoric acid etched, wet dentin substrates. *Dent. Mater.* 14: 347-352.
- Martinez-Insua A, Da Silva Dominguez L, Rivera FG, Santana-Penin UA (2000). Differences in bonding to acid-etched or Er:YAG-laser-treated enamel and dentin surfaces. *J. Prosthet. Dent.* 84: 280-288.
- Mehl A, Kremers L, Salzmann K, Hickel R (1997). 3D volume-ablation rate and thermal side effects with the Er: YAG and Nd: YAG laser. *Dent. Mater.* 13: 246-251.
- Moll K, Park HJ, Haller B (2005). Effect of simulated pulpal pressure on dentin bond strength of self-etching bonding systems. *Am. J. Dent.* 18: 335-339.
- Oliveira SS, Pugach MK, Hilton JF, Watanabe LG, Marshall SJ, Marshall GW Jr (2003). The influence of the dentin smear layer on adhesion: a self-etching primer vs. a total-etch system. *Dent. Mater.* 19: 758-767.
- Ozturk AN, Belli S, Eskitascioglu G (2004). The in vitro effect of pulpal pressure and luting agent on tensile bond strength of complete cast crowns. *J. Prosthet. Dent.* 91: 253-257.
- Pioch T, Staehle HJ, Schneider H, Duschner H, Dörfer CE (2001). Effect of intrapulpal pressure simulation in vitro on shear bond strengths and hybrid layer formation. *Am. J. Dent.* 14: 319-323.
- Sauro S, Pashley DH, Montanari M, Chersoni S, Carvalho RM, Toledano M, Osorio R, Tay FR, Prati C (2007). Effect of simulated pulpal pressure on dentin permeability and adhesion of self-etch adhesives. *Dent. Mater.* 23: 705-713.
- Sengun A, Unlü N, Ozturk B, Ozer F (2005). Microtensile bond strength of two resin composite materials placed with direct and indirect techniques under simulated pulpal pressure. *J. Adhes. Dent.* 7: 197-202.
- Stern RH, Sognnaes RF (1965). Laser effect on dental hard tissues. A preliminary report. *J. South. Calif. Dent. Assoc.* 33: 17-19.
- Tay FR, Sano H, Carvalho R, Pashley EL, Pashley DH (2000). An ultrastructural study of the influence of acidity of self-etching primers and smear layer thickness on bonding to intact dentin. *J. Adhes. Dent.* 2: 83-98.