

## Full Length Research Paper

# Determination of mechanical characteristics and reaction to fire of “RÔNIER” (*Borassus aethiopum Mart.*) of Togo

O. D. Samah<sup>1</sup>, K. B. Amey<sup>2\*</sup> and K. Neglo<sup>2</sup><sup>1</sup>Centre de la Construction et du Logement, Cacavelli BP. 1762 Lomé, Togo.<sup>2</sup>Ecole Nationale Supérieure d'ingénieurs (ENSI), Université de Lomé, BP 1515, Togo.

Received 6 August, 2014; Accepted 15 December, 2014

The “rônier” or *Borassus aethiopum Mart* is a wood material which is used as an element for construction and public works in Togo. The goal of this study was to determine its mechanical characteristics and its reaction to fire which are the fundamental parameters of works dimensioning. The analyses and tests of *B. aethiopum* samples enabled to realize that the *B. aethiopum* possesses mechanical features much superior to those of resinous and leafy wood (1.08 times for the pruning to 2.5 times for the axial drive). The resistance to the axial compression is 3.5 times the transversal one. With a strong content in cellulose, the use of the *B. aethiopum* should be avoided at temperature exceeding 180°C. For a temperature of 676°C for 2 min, with a humidity of 8.17%, the sample of *B. aethiopum* lost 78.54% of its weight.

**Key words:** Togo, *Borassus aethiopum*, mechanical characteristics, reaction to fire.

## INTRODUCTION

The Togolese population prefers to use the rônier, currently called “cocker” rather than other woods in the building of houses and lintels (Samah, 1998). The rônier, scientifically called *Borassus aethiopum* is a material that can be found locally. It is the kind of spermatophyte angiosperme of the class of monocotyledons belonging to the family of Arecaceae. It is used in different construction activities, especially in the works of civil engineering. The rônier develops a smooth and grey stipe that, at the adult age, measures 15 to 20 m and provides an aspect of a slightly thickened column from the start and strongly swollen in

the middle (Diallo, 1987).

In Asia, it was cultivated for its sugar and other uses, especially the construction (wood, leaves); in this area, though it faces a competition from other material such as bamboo, it derives its prestige from its unrivaled quality of resistance. It is a material that does not rot and stands sea mollusk (Tsybousky et al., 1971). In Togo, though data are not available on wooden characteristics from rônier, it is mostly used. Indeed, a test on traditional buildings in Togo, carried out in “cocker”, showed that time and bad weather have no impact on their elements and the “cocker”

\*Corresponding author. E-mail: ameykoss3@yahoo.fr.

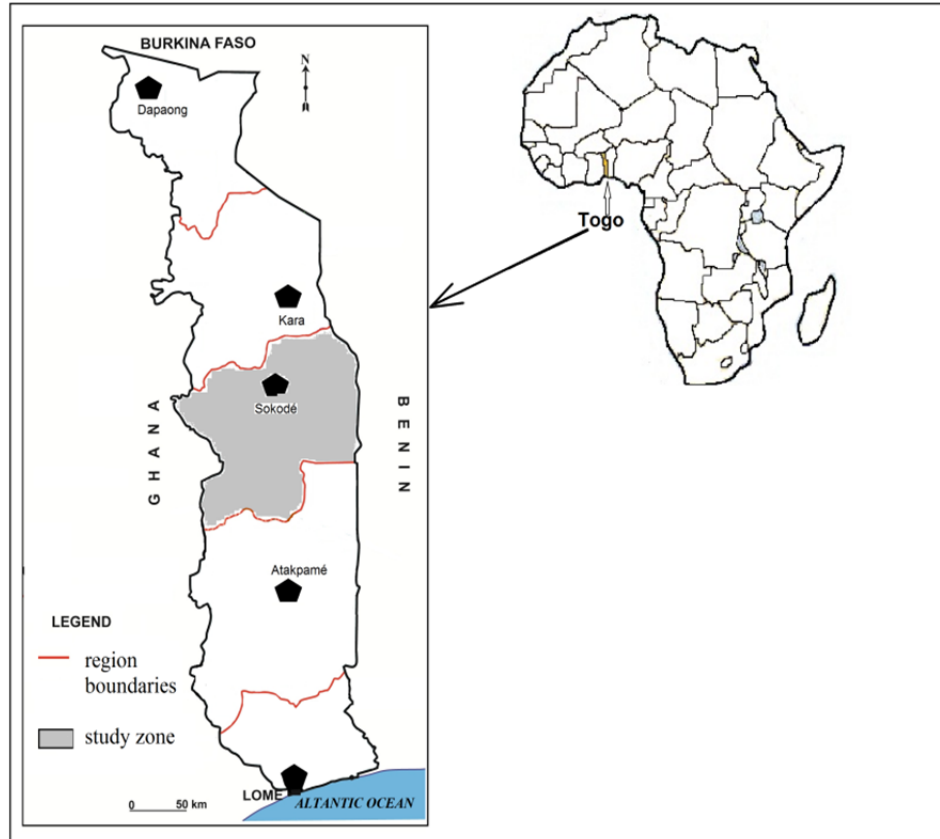

Figure 1. The map of Togo showing the study zone.

left no sign of aging and deterioration by water, humidity, insects and mollusks (Tsyboulsky et al., 1971); but its use is old-fashioned, which can be dangerous for the works if dimensions of parts of works become too weak.

Our study consists in searching the characteristics of this rônier material that is complex and used in the constructions in Togo according to the required direction. We sampled woods of rônier that we tested to determine mechanical features and to fire-proof. The following tests were therefore carried out: Resistance to the compression, traction, flexion and pruning; resistance to fire.

## MATERIALS AND METHODS

In order to conduct this study the experimental device consisted of: a universal hydraulic press of the kind UPD-10 with a maximum pressure of 10 000 kPa; a ventilation oven (60 to 200°C), volume 393 L, weight 175 kg, and power 6600 watts; an oven (40 to 180°C); volume 25 L, weight 29 kg, and power 500 watts; an electric scales of the kind Sartorius model A2005F1 with maximum mass of 202 g, precision of 0.0001 g; a Roberval's balance with flaw and maximum mass of 25 kg; a metallic tube that is 165 mm long, 50 mm diameter with a burner tip of 7 mm; a manufactured domestic gas as fuel; a chronometer; wood test tube from rônier, cut according to the type of test; metallic mould and laboratory mixer for constructing concrete test tube.

## Method

The rônier used for this study was taken from the central region of Togo as is shown in Figure 1. Due to the texture of rônier wood that is very fibrous, heterogeneous and anisotropic, the samples collected were from stems that were taken from the inferior half of the rônier trunk outside the core of the trunk. The following two series of test were carried out: on one hand, a series on samples in the parallel way to fibers of these latter: axial load; on the other hand, a series on samples but in the perpendicular way to the fibers.

Tests of compression were conducted on cubic samples of 25 mm of ridge with the help of universal hydraulic press of the kind UPD-10. The constraints of axial compression (0°) or perpendicular (90°)  $f_{c,0}$  or  $f_{c,90}$  are determined by the following expression:

$$f_{c,0 \text{ ou } 90} = \frac{N_{c,0,90}}{S_{c,0,90}} \quad (1)$$

With  $N_{c,0,90}$  load crushing axially applied (0°) or perpendicular to fibers in N and  $S_{c,0,90}$  surface of crushing of the sample in  $\text{mm}^2$

Tests of traction on the samples of section 30 x10 mm and of length 750 mm in the parallel way to the fibers are only made in the parallel way (0) to the fibers. The crushing is carried out on universal hydraulic press of the kind UPD-10. The constraints of axial traction are determined by the following expression:

$$f_{t,0} = \frac{N_{t,0}}{S_{t,0}} \quad (2)$$

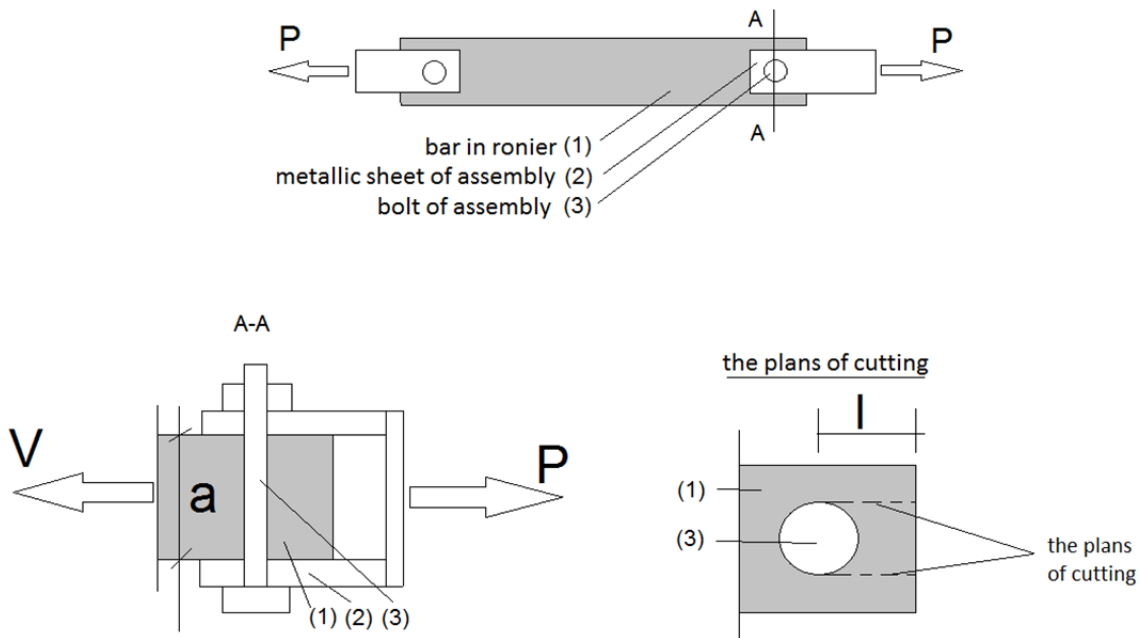

Figure 2. The setting-up device of the cutting test.

Whereby  $N_{t,0}$  is load crushing axially applied ( $0^\circ$ ) to fibers in N and  $S_{t,0}$  the surface of crushing of the sample in  $mm^2$ .

The universal hydraulic press of the kind UPD-10 enabled to determine the bending strength of the rônier (cocker). The tests are carried out on the sample with dimensions 15 x 30 x 800mm.

The expression of the constraint of bending ( $f_m$ ) on the extreme fibers (positioned to  $y=h/2$ ) of the neutral axe of the bar is given by:

$$f_m = \frac{3PL}{2h^2b} \quad (3)$$

Where,  $f_m$  is constraint of bending in MPa,  $P$  being the load of crushing applied to half-reach in N,  $L$  being the reach of the bar (distance between the two press hold) in mm and  $h$ ,  $b$  the height and the length of the section of the bar in mm.

The test of pruning is made in the axial way. The setting-up device is given in Figure 2.

The expression of the constraint of pruning ( $f_v$ ) is given as:

$$f_v = \frac{V}{2la} \quad (4)$$

With  $V$ , the load of pruning in N,  $a$  the length of the room and  $2l$  the two lengths of the plan of pruning (Figure 2).

The test of the fire-proof is also conducted on the purpose of appreciating the resistance to fire of our material. The sample with a unit of initial humidity of 8.17% is set on fire at a temperature of  $676^\circ C$  for 2 min. Weights before and after the test enabled to determine the burning effect that is observed by appreciating the loss of weight of test tubes.

The appreciation of the resistance to fire of woods is carried out as follows: a material that is far from fire and stops burning is considered as resistant to fire if it loses less than 20% of its weight; a material that is far from fire and burns, but if after 5 min the fire dies out, it is considered as somewhat resistant to fire; a material that is far from fire and burns easily, is considered as non resistant to fire if it loses more than 20% of its weight.

## RESULTS AND DISCUSSION

The summary of results on the average values of mechanical tests (traction, compression, flexion and pruning) and the characteristic values of leafy and resinous woods are shown in Figure 2 (Benoit et al., 1995). As for Figures 3 and 4, they give graphic illustration of results.

Figure 3 shows a significant difference between the constraints in axial traction (105 MPa), in axial compression (92.5 MPa) and in perpendicular compression (26 MPa); which confirms the anisotropic aspect of the rônier (Figure 4)

The results also show that the resistances of rônier are very high in the axial direction (axial compression: 92.5 MPa; axial traction: 105 MPa; which confirms the behavior of this material as a fibrous, rigid, and hard resistant material (Table 1). On the other hand the resistance is very weak in the transversal direction (perpendicular compression: 26 MPa); the wood therefore behaves like a plastic deforming material (Benoit et al., 2009). It is also noticed that the resistance to the axial compression is 3.5 times that which is perpendicular to fibers; this ratio is 3.72, according to the works of GBAGUIDI et al. (2010), on the rônier in the Republic of Benin; it is only 2.52 in the highest gap for the case of characteristic constraints of ordinary woods. This very important difference of resistance to the axial compression and to that of the perpendicular compression (3.5 times) is due to the presence of fibers. These fibers would be very rich in cellulose, agent responsible for the resistance of the woods. Indeed, the cellulose is the constituent of the wood that plays the role of support of the mould in pectolignous cement

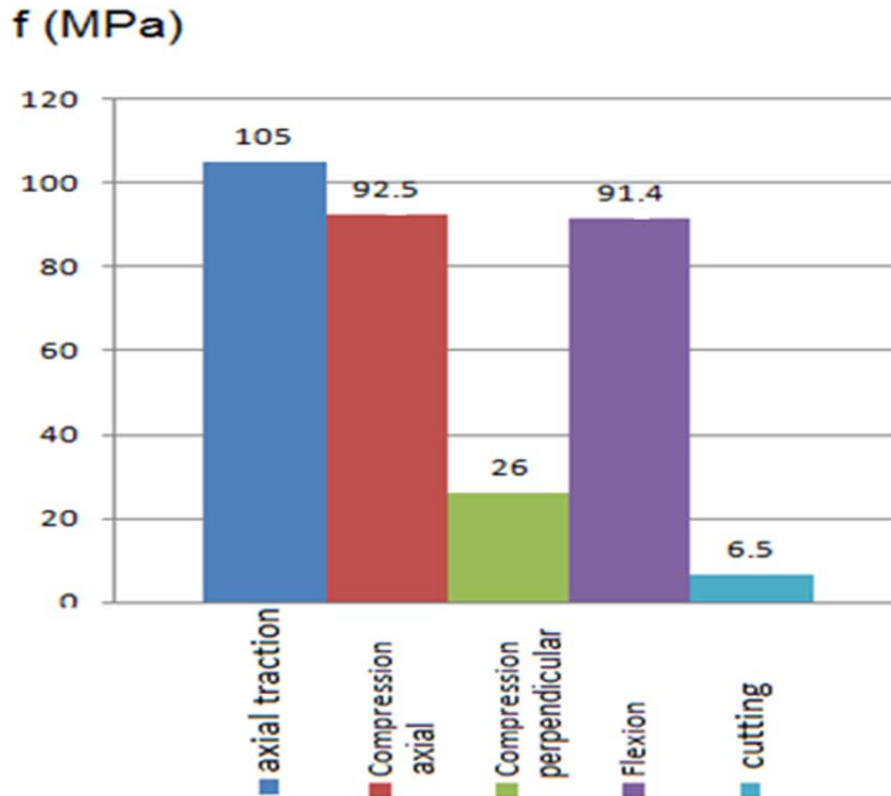

**Figure 3.** The constraints of breaking up of rônier.

**Table 1.** Resistances of “rônier” and woods.

Average Values (MPa)	Type of wood	Axial traction (MPa)	Compression (MPa)		Flexion (MPa)	Pruning (MPa)
			Axial	Perpendicular		
Rônier	-	105	92.5	26	91.4	6.5
Resistances 4	Leafy and woods	18 to 42	23 to 34	8 to 13.5	30 to 70	3 to 6
	Resinous woods	8 to 24	2 to 2.9	2 to 2.9	14 to 40	1.7 to 3.8

(Kompella et al., 2002). It is important to note that the cellulose deteriorate at a temperature exceeding 180°C with gas emission (Champetier, 1959).

The constraints of breaking up of the rônier are much higher than those of leafy and resinous woods that are the most resistant (Figure 4); the ratios of resistance of rônier on the wood resistance are: resistance to axial traction: 2.50; resistance to axial compression: 2.75; resistance to perpendicular compression: 1.93; resistance to axial traction: 1.31; resistance to pruning: 1.08.

According to GBAGUIDI's works (EROCODE 5, 1995), the constraint of breaking up to the traction is 303 MPa, while it is 105 MPa according to the study. This difference would be due to the complex aspect of the rônier wood the features of which are linked to its chemical composition (cellulose, hemicelluloses, lignin, extractives etc.)

and the different proportions of component are also based on kinds, climate conditions, the age of the plant etc. (Kollmann et al., 1984)

The fire proof test resulted in a loss of weight of the test tube of 78.54%, which is superior to 20%. This allows concluding that the rônier belongs to the group of ligneous materials that are not resistant to fire. Thus, the rônier will start losing its mechanical characteristics and becomes almost inexistent at the temperature of 676°C. However, the fibres, with their significant resistances, would be resistant to alterations due to insects, mushrooms and microorganisms; which would free them from prior protections (Tsybousky et al., 1971)

The very high resistance of the *B. aethiopum* “rônier” gives it the characteristic of a material that is much adapted even better to the construction works of civil

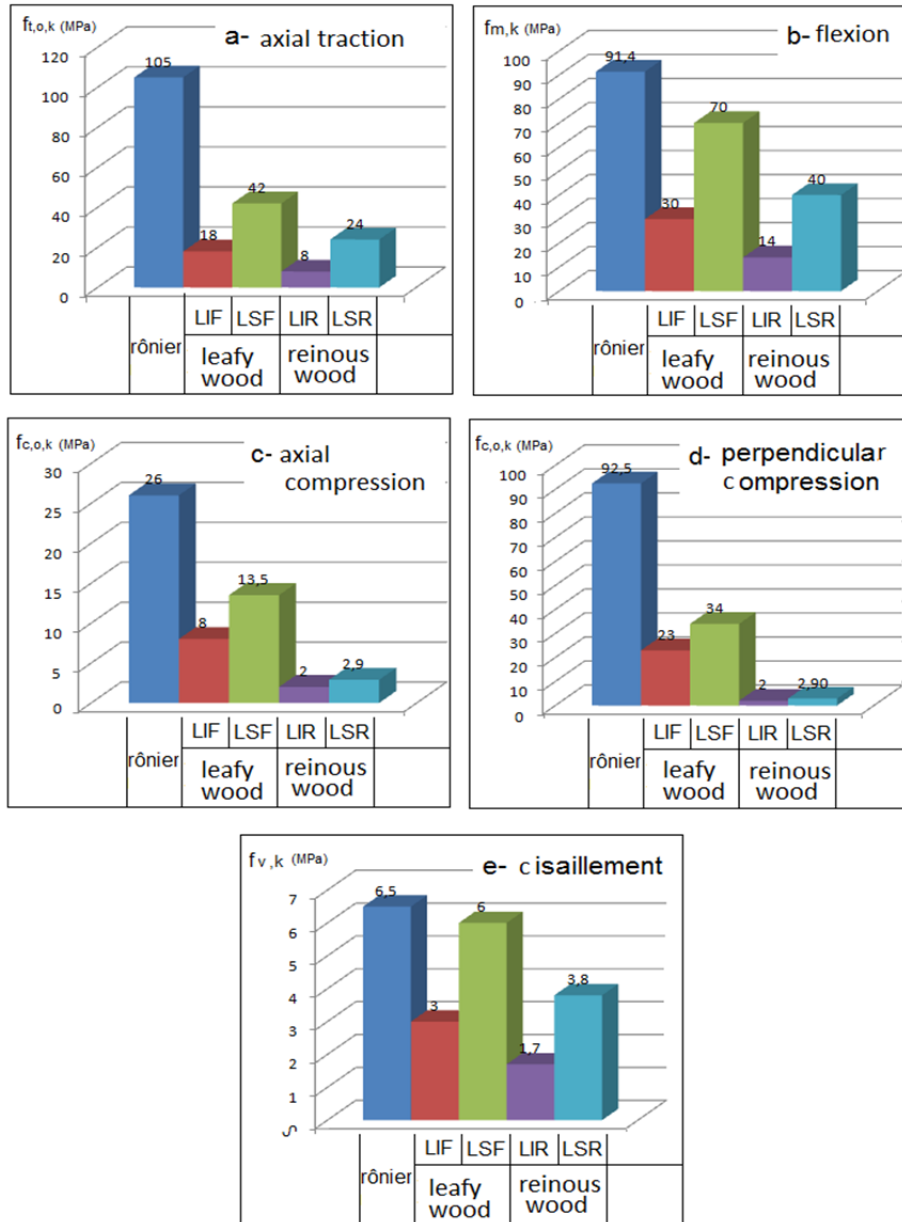

Figure 4. The constraints of the rônier and woods.

engineering for the parts of works in: traction: tie-rods, strained ribs of lattice work truss; compression: posts and compressed ribs of lattice work truss; flexion beams, lintels at the openings in the buildings and trusses with full soul of framework.

Their usage has to be reduced for works that are exposed to temperature higher than 180°C.

**Conclusion**

This study has identified some mechanical characteristics of *B. Aethiopum* needed for works of civil engineering design studies. The behavior of this material was also tested in the presence of high temperature. It emerged

from the analysis that, this material possesses resistance strength of 1.08 times to pruning and 2.5 times to axial drive than to resinous and leafy wood. Its resistance to the axial compression is 3.5 times than that of the transversal one. The use of the material should be avoided at a temperature above 180°C. The use of this material in constructions must be accentuated and encouraged especially for works such as: frames, architraves and columns.

**Conflict of interests**

The authors did not declare any conflict of interest.

## REFERENCES

- Benoit Y, Legrand B, Tastet V (2009). Calcul des structures bois – guide d'application. 2<sup>ème</sup> édition. Amendement A1+feu+vent. Edition Eyrolles.
- Champetier G. (1959). Les fibres textiles, naturelles, artificielles et synthétique. Collection Armand Collin. Paris. Pp 10-40.
- Diallo M (1987). Le comportement du rônier (*Borassus Aethiopum*) dans les rôneraies paysanes des régions de Fatick et de Thiès, Sénégal. Université de Laval (Québec).
- Gbaguidi VS, Gbaguidi-Aisse LG, Gibigaye M, Adjovi E, Sinsin BA, Amadji A (2010). Détermination expérimentale des principales caractéristiques physiques et mécaniques du bois du rônier (*borassus aethiopum* mart.) d'origine béninoise : Cas des poutres. JRSUL Lomé (Togo). Série E, 12(2):1-9.
- Kompella MK, Etlambros J (2002). Micromechanical characterization of cellulose fibers. *Polym. Test.* 21(5) :523-530.
- Kollmann FP, Côté WA Jr (1984). Principles of wood science and technology. Springer Series in Wood Science, I, NY, USA 592p.
- Samah OD (1988). Utilisation des matériaux locaux dans la construction des ouvrages du Génie Civil : Le cocker : caractéristiques et utilisation. CCL Cacaveli.