

International Journal of Arts and Humanities (IJAH)

Ethiopia

Vol. 6 (4), S/No 23, SEPTEMBER, 2017: 22-36

ISSN: 2225-8590 (Print) ISSN 2227-5452 (Online)

DOI: <http://dx.doi.org/10.4314/ijah.v6i4.3>

Utilizing Indigenous Elements on Akwa-Ocha for Modern Fabric Design and Garments

Onwuakpa, Lovina Ebele

Department of Fine Arts and Design

University of Benin, Benin City

Rivers State, Nigeria

+2348023848085

Abstract

Akwa-Ocha, which literally means white cloth, is a popular hand-woven cloth among the Enuani people, who are also referred to as Aniocha people in present day Delta State in South-south geographical zone of Nigeria. The cloth is designed and woven for all-purposes but can also be customized to suit particular occasions or client of high social status. *Akwa-Ocha* is embellished with motifs and symbols reflective of the people's religious as well as social beliefs. These motifs range from mundane to the spiritual and incorporate plants, animals, man-made objects, geometric shapes, as well as cosmological symbols. Beyond their ordinary function of clothing the wearers, *Akwa-Ocha* woven cloths assume other important and symbolic roles, such as social and other ritual significance. How did this cloth gain such significance among the Aniocha people? Does such importance offer any interpretation of the changing social political landscape in modern Nigeria? In what ways have *Akwa-Ocha* responded to global fashion consciousness? As a treasured item, *Akwa-Ocha* is among the most important two-dimensional art forms in Nigeria. It is the intention of this paper to address some of the further developments with its motifs and symbols. This paper will argue that globalization has created other responsibilities for even further broadening the utility value of the motifs and symbols inherent on the cloth, and also making it accessible to a wider range of users.

Key Words: Motifs, *Akwa-Ocha*, modern fabric design, indigenous elements, Delta-Ibos.

Introduction

Nigeria has a tradition of cloth making and decoration. This is because one of the ways Nigerians exhibit their identity and heritage is through their art and crafts traditions

particularly textiles and fashion. They cherish outfits in which they show their culture and identity. Indeed, Nigerian people are culturally conscious of their dress or fashion considering the fact that virtually every ethnic group has its own indigenous fabrics and dress style that is enduring. Nigerian indigenous cloths are mostly hand-woven and are exciting for their rich and wide range of styles, beauty in colour, and vibrant surface patterns; and they constitute a primary example of cultural vitality. It is not surprising therefore that Sieber (1974) noted that each culture evolves its own distinctive fashion that serves to distinguish it from another group. Akinrujomu (2002) also informed that fashion is different from tribes and ethnic groups and may be permanent or changing.

Many ethnic groups are identified with specific fabrics. The Ebira are known for Okene cloth while the Tiv produce and wear their own cultural cloths called Tiv cloths. Tiv clothes include *Anger*, *Tugudu*, *ashisha*, *achubu* and *gberave*. Among these Tiv clothes, *Anger* is the most popular. The Hausa are popularly known for *Danshiki* clothes. The Fulani produce and wear a woven cloth called *Kassa*, and the Ibibio are known for their cultural cloth known as *Ukatt*. The Ndoki are known for *Akwete*. The Igbo speaking people of Delta State produce and wear their woven white cloth called *Akwa-Ocha*. Although many of these local cloths have been integrated into modern fashion, Diogu (2002) informed that local cloths are usually heavy and this affects the comfort and suitability of the cloths for use as common clothing fabrics. In essence some of them are unsuitable to accommodate modern fashion styles.

***Akwa-Ocha* Hand-woven Cloth**

Akwa-Ocha hand-woven cloth is very popular among the Delta Ibos speaking people of Enuani, who are also referred to as Aniocha. Different scholars have also associated *Akwa-Ocha* with the Aniocha people. According to Oyanna (2015) *Akwa-Ocha* is the native immaculate white wrapper that is peculiar to the Aniocha people of the Delta State. For Oguah (2013), *Akwa-Ocha* is the traditional cloth worn and used by the Aniocha tribe of Delta state otherwise known and referred to as Delta Ibos.

Akwa-Ocha is usually embellished with motifs and symbols reflective of the people's religious as well as social beliefs. These motifs and symbols incorporate plants, animals, man-made objects, cosmological symbols as well as past historical events. The motifs and symbols or design patterns on *Akwa-Ocha* are also unique and simple both in content and style. These design patterns give the cloth its cultural identity. Some designs on *Akwa-Ocha* are symbolic and their meanings are determined by the source of inspiration. Whatever their origin or meaning, the motifs and symbols on *Akwa-Ocha* are used not only for their aesthetic value but also as a non-verbal communication.

The uses of *Akwa-Ocha* are numerous. Beyond their ordinary function of clothing the wearers usually in wrapper form, *Akwa-Ocha* assumes other important and symbolic roles such as social, ritual and religious significance. Okeke (1980) opined that Aniocha people use their *Akwa-Ocha* for most of their ceremonies believing that it inspires certain mystic essence in ceremonies and rituals. The use of *Akwa-Ocha* beyond their ordinary function of clothing the wearer exemplifies Perani and Wolff (1999) view that Africans use cloth to dress and to do things important to them. However, since *Akwa-Ocha* is readily available in wrapper form, at every occasion or ceremony it is put to use, the men combine the cloth which they tie around the waist region with a singlet or

T-shirt (Plate 1). For the women, they either tie *Akwa-Ocha* above their breast or around the waist with a matching blouse (Plate 2 and 3).



Plate 1: A man wearing Ibe Akwa Ato (three-piece wrapper) with a singlet.
Date: 2014
Courtesy: Lovina Ebele Onwuakpa



Plate 2: A young woman wearing Ibe Akwa nabi (two-piece wrapper) without a blouse
Date: 2014
Courtesy: Lovina Ebele Onwuakpa



Plate 3: Women wearing *Ojijenantukwasi* (three-piece wrapper over two pieces) with a blouse and headgear

Date: 2014

Courtesy: Lovina Ebele Onwuakpa

Since Nigeria is a country with mixed fashion and is undergoing changes at rapid pace, the importance of *Akwa-Ocha* has offered some interpretation to the changing social and political landscape in modern Nigeria. This is because anyone who adorns *Akwa-Ocha* at any ceremony does so as a mode of identity. For example, the fact that people often adorn *Akwa-Ocha* at socio-political ceremonies is an indication that this local fabric never goes out of fashion despite the influences of globalization. Again, it is to showcase the rich culture of the particular region or ethnic group in Nigeria. More so, apart from giving the wearers an identity, *Akwa-Ocha* highlights creativity and often makes the individual wearing it to stand out in a crowd.

There can be no doubt that the concern over the rate of globalization has continued to affect Nigerian fashion consciousness both in choice and demand. Ultimately global fashion consciousness changes because many people keep demanding for new and different styles. For example, there has been more preference for foreign designs or fashion which are believed to have better working properties, are available in large quantities and in different modern styles. However, as these demands and changes occur, *Akwa-Ocha* has not responded to this global or modern fashion consciousness. This is because *Akwa-Ocha* is only readily available in wrapper form. The cloth is also heavy, coarse and less soothing in nature; hence these affect the comfort and suitability of the cloth for use as common clothing fabric or modern dress styles.

Based on the above, *Akwa-Ocha* seems to be less functional and the future of the cloth looks bleak because its appeal is fast declining. In addition, many of these clothes are now used as souvenir or confined in boxes. This development has necessitated the need to make some of the values inherent in *Akwa-Ocha* such as its motifs and symbols exists in lighter cotton fabric such that it can be suitable in modern fashion styles that can attract both local and international interests. This will also serve to create identity in modern Nigerian fashion, propagate the people's cultural heritage, and serve as urgent remedy to particularly document and save the motif and symbols on the fabric.

Since globalization has created other responsibilities for even further broadening the utility value of the motifs and symbols inherent in *Akwa-Ocha*, it is therefore the intention of this paper to present and discuss some new modern fashion innovations designed with these cultural elements. These new fashion innovations are also made accessible for wide range of users.

Presentation and Analysis of New Fashion Innovations Designed with Akwa-Ocha Motifs and Symbols

The work titled *Our Pride* (Plate 4) was inspired by *Akwa-Ocha* hand woven cloth motifs arranged in exotic styles. *Akwa-Ocha* motifs employed in the design of the fabric worn by the model include the Nigerian flag and the step. The design on the fabric was achieved through the screen printing technique. The placement of the motifs does not follow any canonized rule but a harmony of the Nigerian flags and steps motifs combined together in a way that is somewhat appealing as a design to express national pride and identity in modern fashion trend. The fabrics, which measure five yards, has brilliant colour of deep pink. The end-use in tailored top female jumper and trouser contain a lilac colour as its background. The motifs which appear in green and white colours create a contrast with the background colour as they demonstrate two basic designs. The first shows a continuous play of Nigerian flags. The other is a stylistic arrangement of series of triangular forms. One can say that the motifs employed for the design of this piece may not carry the same symbolic meanings as those on local hand woven *Akwa-Ocha* cloth, but a way of preserving a valuable heritage and publicizing it in modern fashion. The flag motifs in their green and white colours metaphorically alludes to the country of Nigeria and the desire at moving Nigeria forward as indicated by the forward facing triangular forms that represents the *Akwa-Ocha* step motif. The end-use is designed to follow the model's outline, covering the outermost part without creating contours. In fact, the patterned piece is shaped to fit the model's dimensions with comfort and ease in perfect harmony with the balance of the model's stance. The

basic pattern making and drawing for the female jumper and trouser is as follows: Jumper: length - 25 inches, waist – 36 inches, bust - 42 inches, hip – 43 inches, shoulder - 16 inches. Trouser: length - 38 ½ inches, waist – 36 inches, width – 21 inches, and ankle (Fig 4a and 4b).



Plate: 4: Title: Our Pride

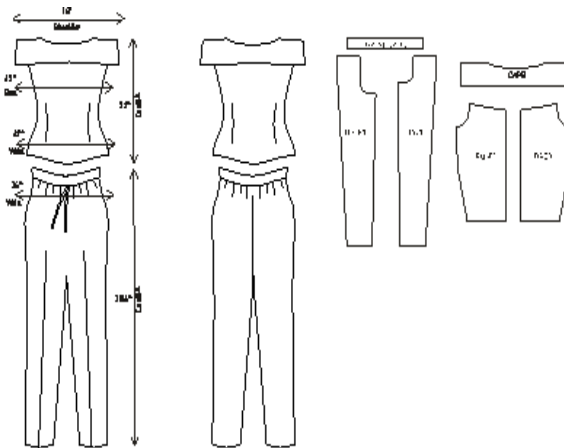

Fig:1 Basic patternmaking sets for the top female jumper and trouser

Size: 5 yards,
 Medium: Screen Printing
 Artist: Lovina Ebele Onwuakpa
 Date: 2016

This piece titled Unity (Plate 5) contains multiple dimensions of decorative elements inspired by *Akwa-Ocha* hand woven cloth. About three distinctive motifs are contained in this work. They include *Nha* (comb) *Ije-agwo* (snake movement) and sugar. The motifs are finely combined to form a pattern or design that connotes unification. The motifs do not appear interlocked but they stress the verbal and visual oneness. These three motifs employed for the design of this piece in their very geometric forms are little removed from reality. There is no focal point in the arrangement of the motifs; however, each series follows a defined movement so that they appear in hints, subtle glimpse rather than obvious references. Each series of motif is somewhat manipulated as a picture plane to form a convenient organic visual compartment. Again, the motifs which appear in deep green colour over a lemon-yellow background and white over a forest green background not only unifies the entire work format but allows for structural depth in the sense that the background colours seem to create windows through which the motifs are seen. This windows effect also creates an impression of spatial depth despite the flatness of the background colour. More so, the dark colour of the motifs against the black background for the five yards fabric and the white colour of the motifs against the Prussian blue background for the tailored short skirt suit create a contrast. The basic patternmaking sets and drawing for the tailored dress in short skirt suit measure- Inner top: length -23 ½ inches, waist – 36 inches, shoulder- 13 inches, hip-40 inches and bust – 39 inches. Measurement for the suit: Shoulder – 14 inches, bust – 40 inches, waist – 37 inches, sleeve width – 15 inches, sleeve length – 23 ½ inches and

hip – 42 inches. Measurement for skirt: Waist – 32 inches, hip – 39 inches and length 21 ½ inches.



Plate: 5: Title: Unity **Fig: 2** Basic patternmaking sets for the short skirt suit

Size: 5 yards
 Medium: Screen Printing and Starch Resist
 Artist: Lovina Ebele Onwuakpa
 Date: 2016

This piece titled Dynamism (Plate 6) is designed to reflect several motifs arranged in stylistic order. The motifs in their geometric triangular and rectangular forms include *lje- agwo* (snake movement) step represented with series of triangles, *Ukwu-efi* (cow leg), *Ukwu-onogbo* or *Ukwu-pussu* (paws of a cat) represented with rectangular forms and *Ego-ayolo* (cowry). The stylistic arrangement of these motifs in different compartment is quite significant which in effect makes them appear dynamic. In fact, the arrangement of motifs or patterns employed for the design of this piece is in a harmonious sequence as manifested in their fluid symmetry. The work format does not have a dominant focus but is entirely covered with numerous intricate designs. The motifs on the five yards draped fabric are rendered in navy blue colour against a white background which makes them appear more visible when viewed at a distance. The motifs used on the fabric for the tailored dress contain orange and navy blue against a white background. The tailored dress is a sleeveless short gown with an alter neck and contains plain and pattern areas. The white area of the design makes reference to the vast sandy plain usually identified within the Aniocha region of Delta State. The model flashes a purse which is also designed with a combination of these motifs in order to complement the entire outfit. The pattern making sets and drawings for the tailored sleeveless short gown measure: Bust – 38 inches, waist -30 inches, hip – 35 ½ inches, length 45 inches and shoulder – 14 inches (fig. 3).



Plate 6:

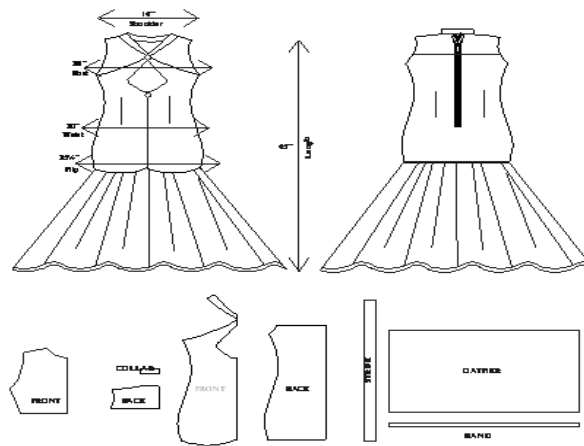

Fig: 3 Basic patternmaking sets for the sleeveless short gown

Title: Dynamism
 Artist: Lovina Ebele Onwuakpa
 Size: 5 yards
 Medium: Screen Printing and Tie-dye
 Date: 2016

This piece titled *Togetherness in Culture* (Plate 7) contains myriads of motifs in their various geometric proportions placed vertically and horizontally. The constitution of motifs derived from patterns on *Akwa-Ocha* hand woven cloth for the design of this fabric include *Mma-eku* (local knife for peeling farm produce such as cassava and cocoyam). Other motifs include *Ije-agwo* (snake movement) represented in zig-zag forms, sugar represented in diamond shape with zig-zag edges and *Akala* (lines). At the edge of this fabric design is a repetition of *Ije-agwo* (snake movement) motif in zig-zag forms that runs the whole length of the fabric. The deep pink and Prussian blue colours against an olive-green background used for the draped five-yard fabric is create harmony. The same harmonious colour scheme applies for the end-use in tailored sleeveless long gown with split with the use of orange and Prussian blue colour for the motifs against an ash colour background. The background colours for draped fabric and that of the end-use are varied in order not to create monotony. The use of warm colours such as deep pink, orange and reddish brown portray living energy and strength in the work. The present of Prussian blue symbolizes eternal love, which is one characteristic in Aniocha cultural practices. The olive green stands for the rich forest belt that is associated with Aniocha region. The tailored long gown could be used for any occasion such as parties. The gown has pleats at the lower region which gives it a more sophisticated look. The neck region is left bear with spaghetti hands so that is can expose whatever jewellery that is adorned around the neck region to complement the outfit. The measurement for the basic block patternmaking sets and drawing for the tailored long gown is as follows: length – 58 inches, waist – 34 inches, shoulder to waist – 16 inches, shoulder – 12 inches and bust -40 inches (Fig: 4).

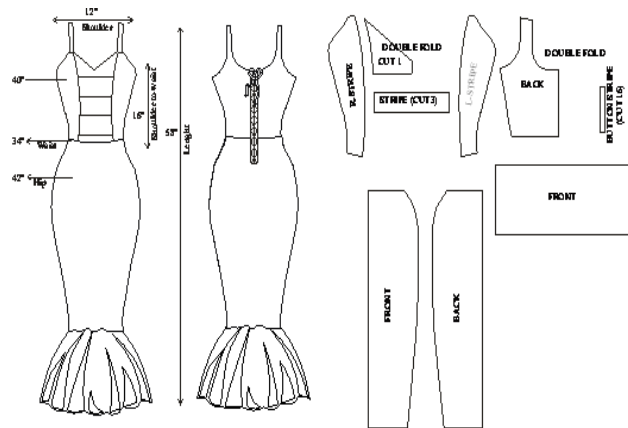

Plate: 7

Fig: 5 Basic patternmaking sets for long gown

Title: Togetherness in Culture
 Artist: Lovina Ebele Onwuakpa
 Size: 5 yards
 Medium: Screen Printing
 Date: 2016

This piece titled Zoomorphic Patterns (Plate 8) contains three different motifs. As the title indicates, the motifs are mostly derived from zoomorphic or animal life. The motifs used for the design of this fabric include *lje-agwo* (snake movement) represented in zig-zag forms, *Ogwu-azu* (fish bone) represented in skeletal form of a fish, *Ukwu-onogbo* or *Ukwu-pussu* (pussy cat paws) represented in geometric square configurations and *Akala* (line) represented in lines. The motifs are deliberately accentuated to have two main qualities but not compromising the principles of design. First, the motifs are made to appear in robustness or bold which makes the entire design format visually soothing and healthy. Secondly, the organic movement of the motif at the border that runs horizontally from top to bottom makes the entire work format manifests as fluid and mobile composition. These qualities are mostly explored on this work while expanding and re-arranging indigenous *Akwa-Ocha* motifs on modern format. The fish bone and pussy cat paws motifs are bound by *Akala* (line) motif in horizontal form. The motifs for the design of draped five-yard fabric appear in brilliant orange colour against a white background. The ones on the end- use in tailored jumper and trouser are in yellow colour against a pulcian blue background. The choice of colour for this and other works create a visual beauty, design creativity and grounded in artistic concept. The tailored dress in jumper and trouser with a round neck was highly structured in proportionate balance to perfectly fit the wearer. Some important features of the dress particularly in the distribution of the motifs, particularly at the neck region and the right and left sleeves are to create balance in the entire design. The basic block patternmaking sets and drawing for this jumper measure thus: length – 33 inches, sleeve width- 18 inches, width – 50 inches and sleeve length - 11 inches. For the trouser: length – 42 inches and waist – 40 inches, thigh-24 inches and ankle - 17 inches (Fig: 5).

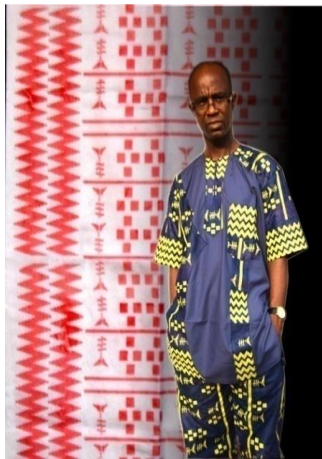

Plate: 8

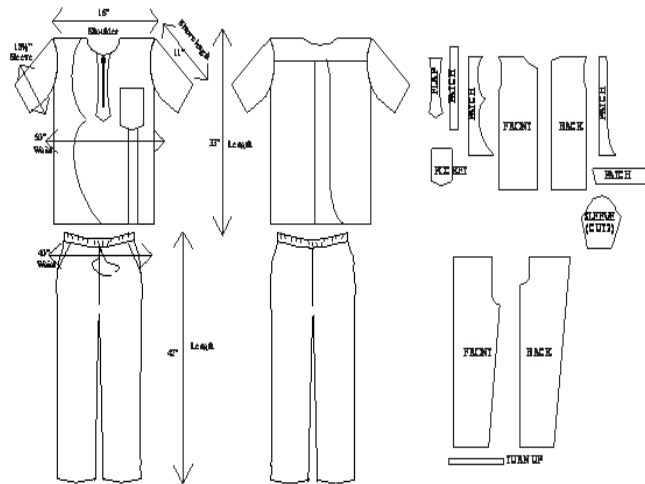

Fig: 5 Basic patternmaking sets for jumper and trouser

Title: Zoomorphic Pattern
 Artist: Lovina Ebele Onwuakpa
 Size: 5 yards
 Medium: Screen Printing
 Date: 2016

The design on this piece entitled *Zoomorphic Expressions* (Plate 9), as in other works, stands out in terms of composition made up of three series of motifs derived from animal life, with each set running in vertical form from top to bottom of the fabric. The discernable motifs used for the design of this fabric include *Ukwu-onogbo* or *Ukwu-pussu* (paws of a cat) which consists of geometric rectangles, *Ogu-azu* (fish bone) represented in fish skeleton, and *Akala* (line). The *Akala* (line) motif has again been used here as in most other works in order to compartmentalize the design formation. However, the motif derived from the paws of a cat in rectangular forms seems more noticeable in this design due to the fact that they appear bolder than other motifs. The fish bone motifs which run beside the aforementioned motif marks the abundance of fish in Aniocha due to the many streams that contain fishes located in the region. One can again notice colour variations as applicable in this design. For example, the background colour of the draped fabric in army green contrasts with the lavish use of yellow colour of the motifs. The army green colour symbolizes the forest belt identified in this region.

The end-use in tailored short and short sleeve shirt with round high neckline contains background colour in Prussian blue and motifs in white colour. The short sleeve shirt is finished off with plain white at strategic areas to create contrast. The short is also finished off with plain white in front, while the back area in patterned. This dress could be used as a casual or evening wear. The patternmaking sets for the short sleeve shirt measures: length – 30 inches, shoulder – 16 inches, width- 36 inches, sleeve length – 9 inches, and sleeve width – 16 ½ inches. For the short: length - 20 inches and waist– 27 inches (fig 6).



Plate: 9

Title: Zoomorphic Expressions
 Artist: Lovina Ebele Onwuakpa
 Size: 5 yards
 Medium: Starch Resist
 Date: 2016

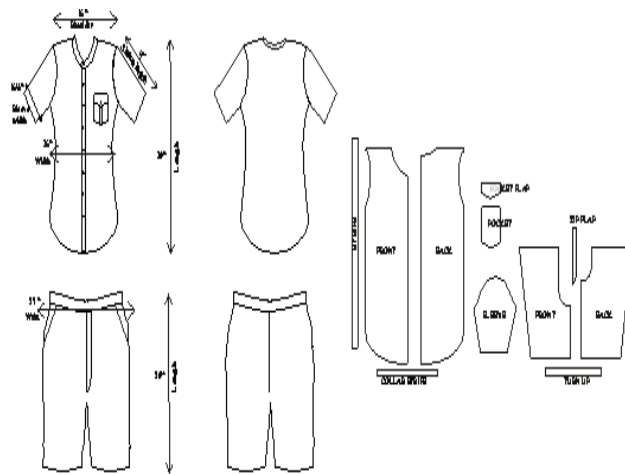

Fig: 6 Basic pattern making sets for the short and short sleeve shirt with round high neckline

This piece titled *Interplay of Patterns* (Plate 10) reveals another interesting combination of motifs. The aesthetics of patterns on *Akwa-Ocha* hand woven cloth from where the motifs were adopted is again strikingly visible in the character of the motifs employed in the design of this fabric. The motifs are arranged in vertical rows demarcated by *Akala* (line) motif. The motifs appear so elaborate and distinctive, covering the whole length and width of the fabric. Four distinct motifs are visible. They include the *Nkpulugo* or *Ego-ayolo* (cowrie) in the colour of white and orange placed one after the other. The second motif is *Ukwu-efi* (cow-leg) represented in right angles triangle in clusters of three rows. The other motif is *Akangweose* (double-headed pestle used for grinding in the kitchen) also in white and orange colours represented as double headed triangle. The deep blue background colour hosting the display of these motifs as a design complements the area in wine colour as contained in the end-use. The end use is a sleeveless basic flared gown with cross neck and several pleats that go round the dress. The pleats created at the lower region are in order to give freedom as well as move with the wearer. The backless style created on this dress is to herald a fashion style based on simplicity. This dress style could mostly be used as a party wear. The patternmaking sets and drawing for the dress measure: bust -34 inches, waist - 32 inches, hip - 38 inches and length - 32 inches (fig. 7).



Plate: 11

Title: Interplay of Patterns
 Artist: Lovina Ebele Onwuakpa
 Size: 5 yards
 Medium: Screen Printing and Tie-Dy
 Date: 2016

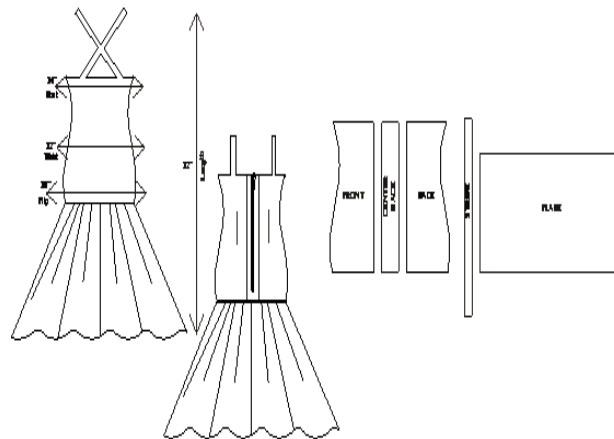

Fig: 7: Basic patternmaking sets for the short gown with X- shape neckline

The effort of the researcher to make use of indigenous elements on *Akwa-Ocha* to design modern fabrics and create garments in a number of modern series each related in a broad thematic concern is exemplified in the work titled *Nzuko Ayanwu* (Plate 12). First, the design on the fabric features only one motif namely *anyanwu* (sun); which motifs are serially arranged in rows. The series of sun motifs appear in black colour against a red maroon background colour. The dress styles tailored with the fabric include short sleeve flare gown, gather gown with braided spaghetti strips, and armless or sleeveless short gown with slit at the lower left corner. One major characteristic that creates a strong visual appeal in the three dress styles and yet highlights the patterned areas; which is an important aspect of their identity, is the inclusion of plain white areas that creates sharp contrast with the red maroon background colour. The pattern plot for the dresses measure: the short sleeve flare gown: shoulder- 13 inches, sleeve length-8 inches, sleeve width- 14½ inches, bust -36 inches, waist- 31 inches, shoulder to waist line- 15 inches and length -36½ inches. For the gather gown with spaghetti strip hands: waist -33 inches, shoulder to waist line - 14 inches, bust-38 inches, and length -37 inches. The armless or sleeveless short gown measure: bust -36 inches, shoulder to waist -13 inches, waist -34 inches, shoulder -12½ inches and length -40 inches. (Fig 8)

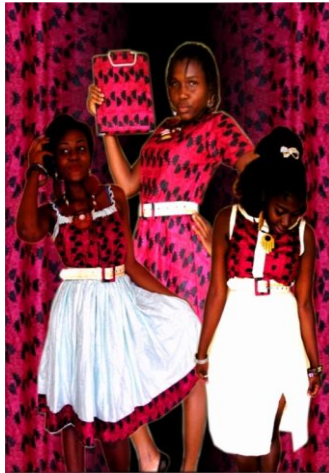

Plate: 12
 Title: Nzuko Anyanwu
 Size: 5 yards
 Medium: Screen Printing
 Artist: Lovina Ebele Onwuakpa
 Date: 2016

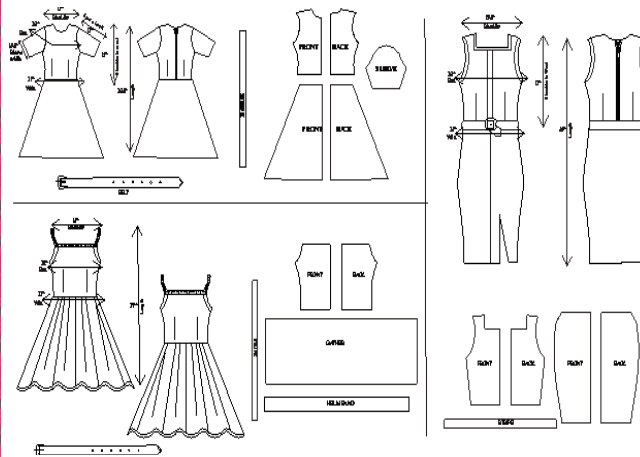

Fig: 8 Basic patternmaking sets for the flared gown, gather gown with spaghetti strip hands and armless or sleeveless short gown

Reference to *Akwa-Ocha* motifs in this work titled *Pride of Place* (Plate 13) again provides more insights that challenge the preconceptions about the richness of Africans indigenous art culture particularly the textile tradition. Here several motifs have been adapted from *Akwa-Ocha* hand woven cloth and combined to create a harmonious design. On this piece there exists three motifs. They include *Akangweose* (double-headed pestle) represented in X shaped form or inverted triangles arranged in three sets, *Ije agwo* (snake movement or zig-zag-trail left behind on the sand by snakes) which is also represented in cluster of zig-zag patterns. These two motifs are demarcated by horizontally/vertically oriented running lines. The choice of colour for the design of this piece is again based on aesthetics and traditional preferences in the sense that symbolically the colour maroon is one of the colours of *Ani* (earth) in the Aniocha concept of colour. The turquoise green colour stands for the greenish tones of the environment's vegetation belt. The motifs so rendered in maroon colour against a turquoise green background is to create a radiant elegance. On the end use one can notice some stylistic distribution of design areas such as on the sleeves, collar, waist and buttons. In order to create more beauty and variety, the end use was finished off by pairing the design areas with plain lemon green fabric. The patternmaking sets for this dress measures: Bust-38 inches, sleeve length-20½ inches, sleeve width-10 inches, shoulder-14 inches and length-37 inches. (Fig 9)

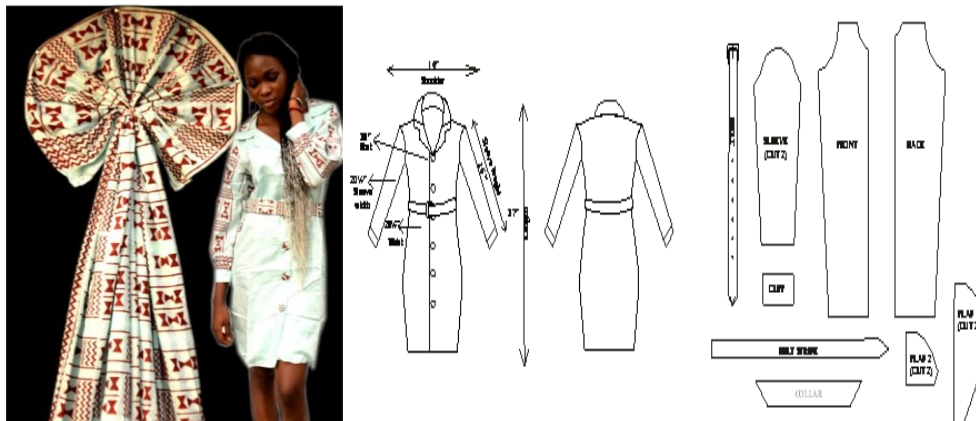

Plate: 9

Fig: 9 Basic patternmaking sets for the Long Sleeve Button Down Short Gown

Title: Pride of Our Place
 Artist: Lovina Ebele Onwuakpa
 Size: 5 yards
 Medium: Screen Printing
 Date: 2016

The meticulous arrangement of design pattern in this piece titled Fortune (Plate 10) creates a sense of order, rhythm, repetition, balance and economy. Three *Akwa-Ocha* motifs are discernible in the design of this fabric. They include *Nkpulu ego* or *Ego ayolo* (cowries) depicted in two rows and *Ukwu-efi* (cow leg) represented in cluster of rear facing right angle triangle. The motifs are demarcated by *Akala* (line) motifs represented with vertical lines. There is no dominant focus in this piece as the entire fabric is covered with numerous intricate designs. The background in deep blue colour presents a sense of sophistication, both in aesthetics and quality. In fact, the deliberate lavish use of deep blue background colour is to give the work a good surface finish and as a unifying factor. Bluish tone is seen as the prominent colour of the sky which signifies heavenly glory in the Anoicha concept of colours. Blue colour also connotes royalty. Among all the motifs employed in the design of this piece, the *Akala* (line) motif has been the reoccurring motif as it is usually manipulated into a sensuous instrument to generate both grouping and unifies the entire design format. The end-use which also appears in deep blue colour hosting series of motifs in white is men's jumper and trouser. Both the jumper and trouser are tailored in a way to respond well to the body characteristics of the wearer, hence philosophy of fit was highly considered. The patternmaking sets for the dress style measure: The jumper or top –length -32 inches, width -40 inches, sleeve width -16 inches, sleeve length-13½ inches, and shoulder-20 inches. And that of the trouser measure: length - 42½ inches and waist - 39 inches (Fig 10)

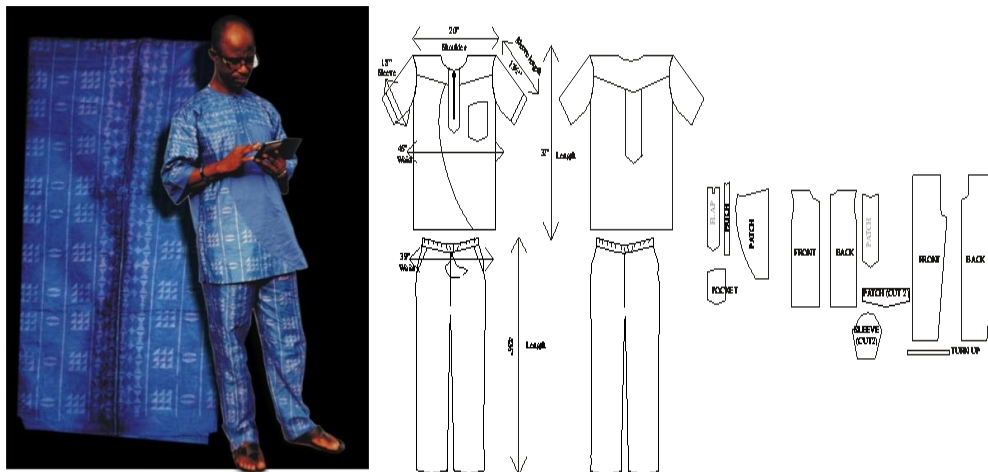

Plate: 10 Fig: 10 Basic patternmaking sets for Jumper and Trousers

Title: Fortune
 Artist: Lovina Ebele Onwuakpa
 Size: 5 yards
 Medium: Starch Resist
 Date: 2016

Conclusion

In conclusion, the challenges, consequences, implications, and the impact of globalization which brought about modern Nigeria fashion consciousness has resulted in the expansion of the utility values of the cultural elements inherent in *Akwa-Ocha* hand-woven cloth. In essence globalization which necessitated modern Nigeria fashion consciousness played a positive role in turning around the fortunes inherent in this important local cloth that was otherwise going into extinction. This development has given rise to reinterpretation of *Akwa-Ocha* motifs and symbols on lighter modern platform.

Since not all globalization has positive impact as it has necessitated more preference for foreign designs, a development which has not given modern Nigerian fashion an identity, if the new fashion innovation designed with *Akwa-Ocha* motifs and symbols is followed, it will not only accommodate the fashion consciousness of Nigerians, but will also serve to create an identity. Again, it will have a far-reaching impact on the emphasis already placed on foreign designs.

References

- Akinrujomu, O. S. (2002). From handmade to machine: An overview of Yoruba textiles. In Agberia, J. T. (Ed.) *Design history in Nigeria*, (pp. 261-268). Abuja: National gallery of art, Abuja and association of African industrial designers.
- Diogu, G. O. (2002). Culture in fabric: The presence in cloth weaving. In Agberia, J.T. (Ed.) *Design history in Nigeria*, (pp. 251-260). Abuja: National gallery of art, Abuja and association of African industrial designers
- Oguah, A. D. (2013). Akwa-Ocha cultural fashion show -facebook. Retrieved from <https://www.facebook.com/events/---/permalink/455055677896506/>
- Okeke, C. S. (1980). *Use of traditional textiles among the Aniocha Igbo of Mid-Western Nigeria textile history*. Edington: The Pasold research Fund, Ltd.
- Oyanna H. (2015). Akwa-Ocha never goes out of fashion. *The Sun Newspaper*. Retrieved from www.newsheadlines.com.ng/---Sun---/2015/---/ Saturday, September 12
- Perani, J. & Wolff, N. H. (1999). *Cloth, dress and Art Patronage in Africa*. Bloomsbury: Berg Publishing.
- Sieber. S. (1974). *African textiles and decorative arts*. New York: The Museum of Modern Art.