

## Comparative study of classical controllers for LFC of an isolated hybrid distributive generation system

Tarkeshwar<sup>1</sup>, V. Mukherjee<sup>1\*</sup>, Almoataz Y. Abdelaziz<sup>2</sup>

<sup>1</sup>Department of Electrical Engineering, Indian School of Mines, Dhanbad, INDIA

<sup>2</sup>Department of Electrical Power and Machines Engineering, Ain Shams University, Cairo, EGYPT

\*Corresponding Author: e-mail:vivek\_agamani@yahoo.com, Tel +91 0326 2235644, Fax. + 91 0326 2296563

### Abstract

In this paper, load frequency control of an isolated hybrid distributive generation (IHDG) following small step load perturbation is analyzed. A powerful quasi-opposition harmony search algorithm has been used for optimization of the controller gains of the studied IHDG model. Performance of some of the classical controllers such as integral (I), proportional–integral (PI), integral–derivative (ID) and proportional–integral–derivative (PID) are compared in the present work. The simulation results show that better control performance in terms of overshoot and settling time has been achieved by choosing PID controller among the other classical controllers considered (such as I, PI and ID). Sensitivity analysis has also been carried out for testing the robustness of the PID controller.

*Keywords:* Harmony search algorithm; isolated hybrid distributive generation; load frequency control; PID controller.

DOI: <http://dx.doi.org/10.4314/ijest.v7i3.16S>

### 1. Introduction

In recent years, the increasing concerns about the limited fossil fuel resources, environmental concerns and increasing demand of energy (Sun & Zhang 2012; Bajpai & Dash 2012) are driving a constantly increasing penetration of renewable energy sources (RES) (like wind, tidal, solar, biomass, geothermal powers). And among these, wind power (WP) and solar power are promising ones. The growing WP penetration is raising due to its stochastic nature, important issues in the operation and control of power systems (Tsili & Papathanassiou 2009). Furthermore, economic attractiveness towards RES has been increased due to government's incentives and the deregulation of energy markets to distributed generation (DG) (Saleem & Lind 2010). One of the major drawbacks of RES based systems is variable and unpredictable energy supply, and thus, resulting in disturbances to the consumer (Costa *et al.* 2008), if uncontrolled.

Stand alone electricity may be generated by a RES system such as using solar photovoltaic panels, wind turbine generators (WTG) or micro-hydro plants or by combining any of these electricity generating sources with diesel engine generator (DEG) and/or a storage device. It is called as isolated hybrid DG (IHDG). Loss of a load or generation may lead to a rapid decrease in the system frequency ( $F$ ) and power ( $P$ ), specially, in an isolated system if the system is operated with an insufficient generation reserve. The systems often include energy storage devices for uninterrupted supply. System controls are used to regulate the whole system operation. So, optimization technique has been applied to optimize the gains of the controllers used in load frequency control (LFC).

In recent years, heuristic optimization techniques, such as genetic algorithm (Goldberg 1989), particle swarm optimization (Kennedy & Eberhart 1995), differential evolution (Storn & Price 1995), harmony search (HS) (Geem *et al.* 2001), bacteria foraging optimization (Passino 2002), gravitational search algorithm (Rashedi *et al.* 2009), seeker optimization algorithm (Shaw *et al.* 2011), cat swarm optimization (Saha *et al.* 2013), cultural algorithms (Ali *et al.* 2013) and so on, have been surfaced in the literature and are being extensively used by the researchers' pool due to their flexibility, versatility and

robustness in seeking global optimal solution as noted time to time. These methods present extreme superiority in obtaining the global optimum and in handling discontinuous and non-convex objectives.

In this work, HS (Geem *et al.* 2001) based optimization has been considered, which is much simpler and more robust optimization algorithm compared to many other well popular optimization methods proposed in the recent past. HS is a derivative-free real parameter optimization algorithm. It has received motivation from the music improvisation process where musicians try to improvise their instruments pitches searching for a perfect state of harmony. HS algorithm imposes fewer mathematical requirements and may be easily adopted for solving various kinds of engineering optimization problems. A few modified variants of HS have been proposed in the literature for enhancing its solution accuracy and convergence rate. A few variant of HS algorithm like global best HS algorithm (Omran & Mahdavi 2008), self-adaptive global best HS algorithm (Pan *et al.* 2010), opposition based HS algorithm (Banerjee *et al.* 2014) have been proposed in the literature for engineering optimization problem. However, in the present paper, quasi-opposition based learning (QOBL) concept is integrated with the original HS algorithm with an aim to accelerate the convergence speed of the basic HS algorithm. Thus, the current study uses quasi-oppositional harmony search (QOHS) algorithm for solving frequency and power deviation problems of the studied power system model.

In view of the above, following are the main objectives of the present work

- (a) To study the IHDG system behavior and characteristics and to develop a small signal model of IHDG
- (b) To apply QOHS algorithm for optimization of the gains of different classical controllers such as integral (I), proportional-integral (PI), integral-derivative (ID) and proportional-integral-derivative (PID) considered individually in the studied IHDG model.
- (c) To compare the dynamic performances of the different controllers as obtained in (b) in order to find out the best controller.
- (d) To determine the robustness of the obtained best controller for this specific application.

## 2. Power Plant Modeling

The dynamic analysis of the IHDG considers DEG, WTG and a storage device (in this case capacitive energy storage (CES)). The blade pitch controller installed in the wind side and the speed governor of the diesel side is equipped with classical controllers. The base capacity of the system is 300 kW (Bhatti *et al.* 1997). DEG helps in maintaining  $F$  and  $P$  level of the system by providing cushions for wind power generator, when wind generator along with the CES unit fails in providing adequate power to the load demand.

The transfer function diagram of the IHDG, used in this study, is shown in Figure 1. This model consists of wind dynamic model, diesel dynamic model, CES unit, classical controller based blade pitch control of WTG and speed governor of DEG. The details of all subsystems are explained in Bhatti *et al.* 1997; Tripathy & Mishra 1996).

## 3. Control Strategy

**3.1 I Controller:** Often control systems are designed using I controller. In this control method, the control systems act in a way that the control effort is proportional to the integral of the error. If the input goes to zero, then the integral stops changing and has whatever value it had just before the input became zero. The integral can change in either direction as the signal goes positive and negative. Negative area may be subtracted from positive area which, ultimately, lowers the value of an integral.

**2.2 PI Controller:** The combination of proportional (P) and I controller is important to increase the speed of the response and also to eliminate the steady state error ( $E_{ss}$ ). The PID controller block is reduced to PI blocks. Without derivative action, a PI-control system is less responsive to real (non-noise) and relatively fast alterations in state and so the system will be slower to reach set point and slower to respond to perturbations than a well-tuned PID system.

**2.3 ID Controller:** The combination of I and derivative (D) controller is important to decrease the settling time ( $t_s$ ) and also to eliminate the  $E_{ss}$ . ID controller is obtained by reducing PID controller. The lack of proportional action may make the system slower. This is because proportional action makes the root locus moves to the left from that pole and thus, time constant becomes smaller.

**2.4 PID Controller:** A PID controller is a control loop feedback controller widely used in industrial control systems. This controller attempts to minimize the error in outputs by adjusting the process control inputs. The PID controller involves three separate parameters, (P, I and D values). These values may be interpreted in terms of time (viz.  $P$  controls the *present* error,  $I$  depends on the accumulation of *past* errors, and  $D$  is a prediction of *future* errors) based on current rate of change. The weighted

sum of parameters (P, I and D values) is used to adjust the process via a control element such as the position of a damper, a control valve, or the power supplied to a heating element etc.

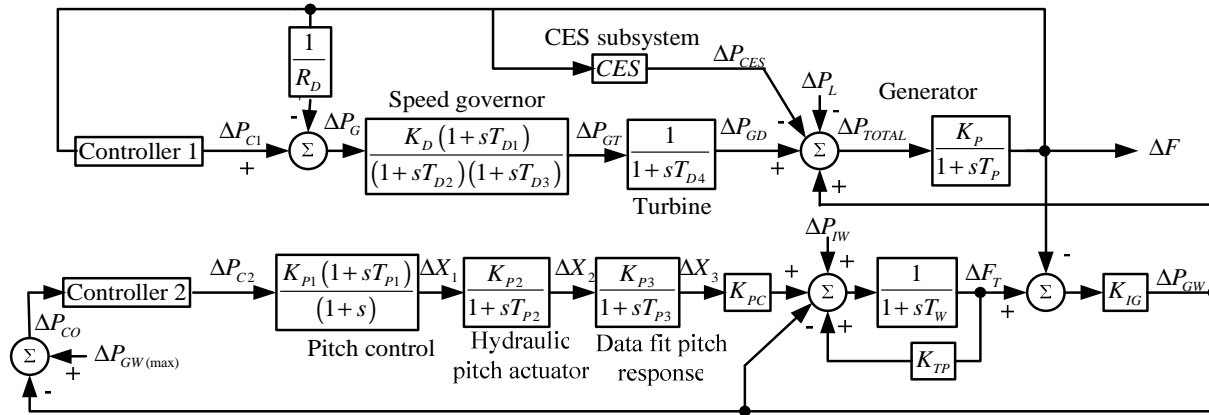

Figure 1. Transfer function model of studied IHGD

As used in this paper, the structure of a PID controller is depicted in Figure 2 and its transfer function may be given by (1) (Zong 2006)

$$G_{PID}(s) = K_P + \frac{K_I}{s} + sK_D \tag{1}$$

#### 4. Mathematical Problem Formulation

Main focus of the present work is to ensure minimal deviation in  $F$  and  $P$  response profiles of the studied IHGD model. This may be achieved when minimized overshoot ( $M_p$ ), minimized  $t_s$ , lesser rising time ( $t_r$ ) and lesser  $E_{ss}$  of deviation in  $F$  and  $P$  response profiles are achieved. The most commonly used objective function is integral of squared error (ISE). ISE is used as fitness function for the optimization of controller gains. Power system configuration, having the least value of ISE, is considered as the best system configuration (Banerjee et al. 2014(a)) and this fitness function is defined by (2)

$$ISE = \int_0^{\infty} |\Delta F|^2 dt \tag{2}$$

#### 5. Optimization Algorithm

5.1 HS algorithm: The interesting connection between music and the process of looking for an optimal solution has led to the creation of the HS algorithm. It is a new kind of meta-heuristic algorithm mimicking a musicians' approach to finding harmony while playing music. When musicians try to create some music, they use one or combination of the three possible methods for improvisation of the created music, which are as follows:

- play the original piece.
- play in a way similar to the original piece.
- play the random notes to creating a piece.

In 2001, Geem et al. (Geem et al. 2001) proposed the similarities between the music improvisation processes and finding an optimal solution to hard problems and formalized the three methods as parts of the new optimization algorithm (the HS algorithm). These are:

- choosing any one value from the HS memory (defined as memory considerations).
- choosing an adjacent value of one value from the HS memory (defined as pitch adjustments).
- choosing totally random value from the possible range of values (defined as randomization).

According to the above concept, the flowchart of HS algorithm is given in Figure 3. So, in the HS algorithm, each musical instrument is represented as a decision variable. The value of each decision variable is set in the similar manner that a musician plays his instrument, contributing to the overall quality of the music created and, thus, the name is coined as HS.

5.2 *QOBL concept*: Opposition-based learning (OBL), originally introduced by Tizhoosh (Tizhoosh 2005), is used to accelerate the convergence rate of different optimization techniques. OBL considers current population as well as its opposite population at the same time. Researchers have proved that an opposite candidate solution has a better chance to be closer to the global optimum solution than a random candidate solution (Rahnamayan et al. 2008). Some of the contributions of OBL in the soft computing field includes opposition- based ant colony optimization (Haiping et al. 2010), opposition-based gravitational search algorithm (Shaw et

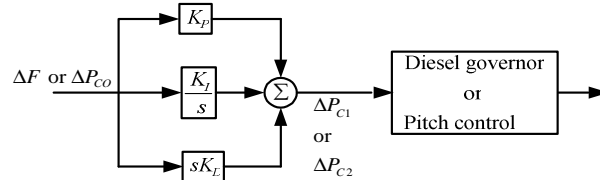

Figure 2. Structure of PID controller

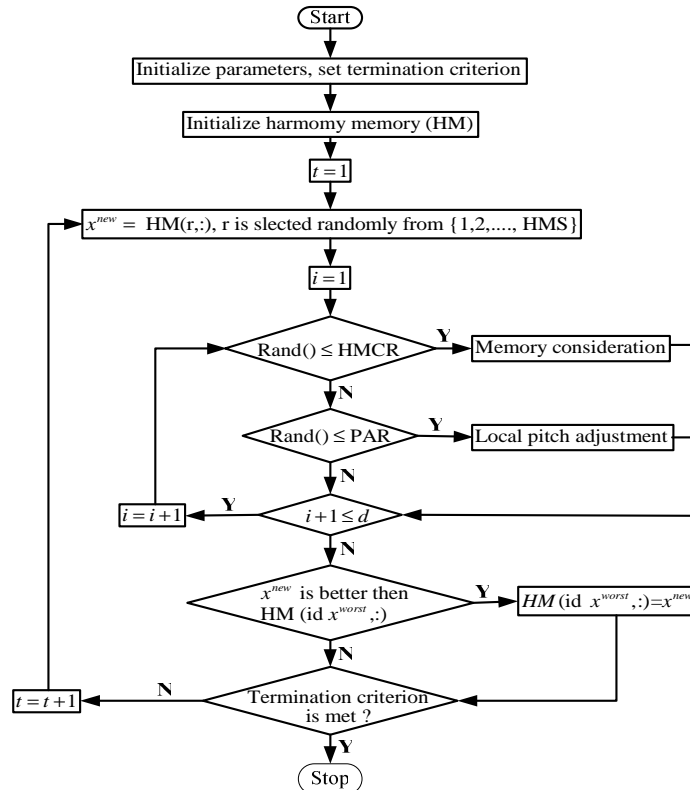

Figure 3. Flowchart of HS algorithm

al. 2012), opposition-based biogeography based optimization (Roy & Mandal 2014) and opposition-based harmony search algorithm (Chatterjee et al. 2012). The opposite number and opposite point used in OBL have a straight forward definition as follows:

5.2.1 *Opposite number*: It may be defined as the mirror point of the solution from the center of the search space and it is mathematically expressed as:

$$x^0 = a + b - x \tag{3}$$

where, a and b are the extreme points of the search space.

5.2.2 *Opposite point*: If  $P(x_1, x_2, \dots, x_i, \dots, x_d)$  is a point in  $d$ -dimensional search space, its opposite point  $OP(x_1^0, x_2^0, \dots, x_i^0, \dots, x_d^0)$  may be defined by (4).

$$x_i^0 = a_i + b_i - x_i; x_i \in [a, b] \quad i = 1, 2, \dots, d \tag{4}$$

However, it is proved that a quasi-opposite number is, usually, closer than an opposite number to the solution (Rahnamayan et al. 2007; Roy & Mandal 2011).

5.2.3 *Quasi opposite number*: It may be defined as the number between the center  $c$  of the search space and the opposite number. Mathematically,  $x^{q0}$  may, be expressed by (5).

$$x^{q0} = rand\left(\frac{a+b}{2}, a+b-x\right) \tag{5}$$

5.2.4 *Quasi opposite point*: The quasi opposite point  $QOP(x_1^{q0}, x_2^{q0}, \dots, x_i^{q0}, \dots, x_d^{q0})$  for  $d$ -dimensional search space is given by (6).

$$x_i^{q0} = rand\left(\frac{a_i+b_i}{2}, a_i+b_i-x_i\right); \quad i = 1, 2, \dots, d \tag{6}$$

5.3 *The QOHS algorithm*: In this article, QOHS algorithm is considered, by employing QOBL concept in original HS algorithm. The implementation steps of QOHS algorithm to solve the studied problem of the present work are described below.

- Step 1. Initial population (P) of the entire individuals is generated randomly within the upper and lower limits.
- Step 2. Quasi-opposite population (QOP) is created using (6).
- Step 3. Values of the objective function for all the individuals of the quasi-opposite population set are evaluated.
- Step 4. Select  $N_p$  (population size) fittest individuals from population (P) and quasi-opposite population (QOP).
- Step 5. Apply HS algorithm.
- Step 6. Feasibility of newly generated solutions are checked and the infeasible solutions are replaced by randomly generated new solutions set.
- Step 7. Using jumping rate, quasi-opposite population is generated from the feasible population set.
- Step 8. Select  $N_p$  fittest individuals from current population and the quasi-oppositional population.
- Step 9. If stopping criteria is satisfied, stop the search process and display the result, else proceeds for the next iteration.

**6. Result and Analysis**

6.1 *Performance comparison of classical controllers*: Classical controllers like I, PI, ID and PID are used in diesel governor and pitch controller. System dynamics are obtained by considering 10% step load perturbation. Every controllers are considered separately and the gains of the controllers are optimized separately by using the QOHS algorithm. Controller gains of the DEG governor and pitch controller of WTG are optimized by using this QOHS algorithm. The obtained optimum values of I, PI, ID and PID controllers are shown in Table 1. Using these optimized gains, the dynamic responses for frequency and power are obtained and these are shown in Figure 4. From this figure it is revealed that the response corresponding to the PID controller are better than the others from the view points of magnitude of oscillations, peak deviations and settling time.

6.2 *Sensitivity analysis*: Sensitivity analysis is carried out to study the robustness of the optimum PID controllers gains ( $K_p, K_I$  and  $K_D$ ) obtained at nominal conditions for wide changes in the system loading condition (by -20% to +10%) from their nominal values. The optimum values of PID controllers gains at different loading conditions are shown in Table 2. Dynamic responses for each changed condition with their corresponding optimum PID gains and PID gains obtained at nominal condition are compared and shown in Figure 5 and Figure 6, respectively. Critical examination of frequency and power responses of Figs. 5–6 clearly reveals that the responses are more or less same. Thus, the optimized values of PID controllers (controller gains of the DEG governor and pitch controller of WTG) obtained at the nominal loading of 80% need not to be reset for wide changes in the system loading.

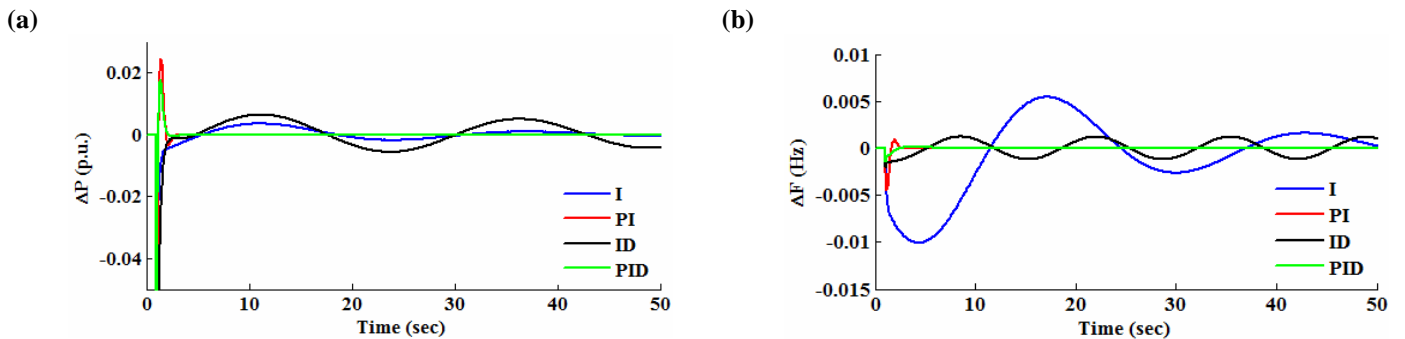

**Figure 4.** Comparison of dynamic response for different classical controllers, (a) deviation of power and (b) deviation of frequency

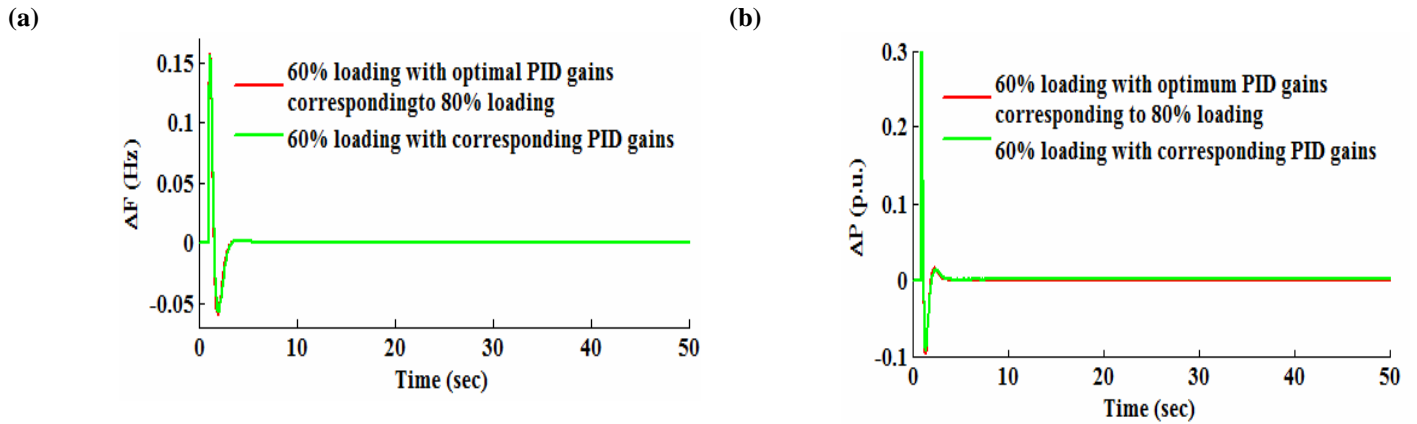

**Figure 5.** Comparison of dynamic responses as a function of time for 60% loading with optimum PID gains corresponding to 60% loading and 80% loading (a) deviation in frequency and (b) deviation in power

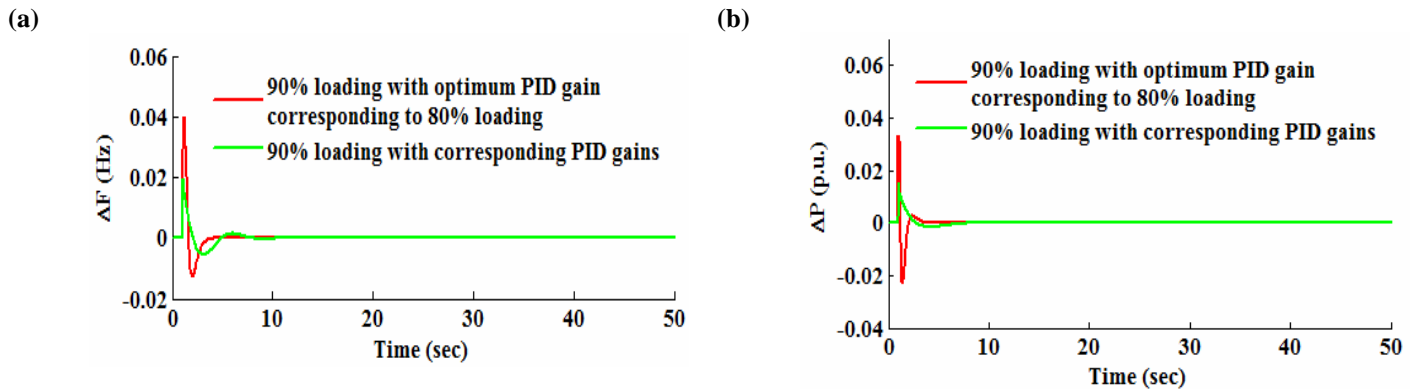

**Figure 6.** Comparison of dynamic responses as a function of time for 90% loading with optimum PID gains corresponding to 90% loading and 80% loading (a) deviation in frequency and (b) deviation in power.

**Table 1.** Optimize value controller gains

Gain Parameters	Type of Controller			
	I	PI	ID	PID
$K_{P\_DIESEL}$	-	99.7455	-	98.7133
$K_{I\_DIESEL}$	00.5315	13.2856	21.8244	65.3436
$K_{D\_DIESEL}$	-	-	98.9133	97.0065
$K_{P\_WIND}$	-	00.0404	-	05.0764
$K_{I\_WIND}$	00.2984	00.2824	05.4489	00.0100
$K_{D\_WIND}$	-	-	17.1565	32.1653

**Table 2.** Optimized value of PID gains at different loading conditions

Gain Parameters	Loading			
	+5%	-5%	+15%	-15%
$K_{P\_DIESEL}$	90.497	91.598	98.077	88.195
$K_{I\_DIESEL}$	84.381	94.246	41.618	89.132
$K_{D\_DIESEL}$	7.1594	5.1141	0.4292	5.7451
$K_{P\_WIND}$	2.2728	0.2011	4.8567	0.3793
$K_{I\_WIND}$	1.0932	0.3666	0.0525	0.8495
$K_{D\_WIND}$	5.3238	9.4132	0.0013	8.4513

**7. Conclusion**

A simplified model of an IHDG model has been developed for its frequency and power deviation performance analysis. All the controller gains are optimized by QOHS algorithm. Classical controllers such as I, PI, ID and PID are individually, considered in the studied IHDG model and their performances are compared. Among all the responses obtained, it is observed that QOHS optimized PID controller is the classical controller whose performance characteristics is better in terms of rise time, settling time, oscillations and overshoot for both frequency and power deviation than other controllers for the studied IHDG configuration. From sensitivity analysis it is also revealed that there is no need for restating the controller values for wide changes in system loading conditions.

## References

- Ali M.Z., Alkhatib K. and Tashtoush Y. 2013. Cultural algorithms: emerging social structures for the solution of complex optimization problems. *International Journal of Artificial Intelligence*, vol. 11, pp. 20-42.
- Bajpai P. and Dash V. 2012. Hybrid renewable energy systems for power generation in stand-alone applications: a review. *Renewable & Sustainable Energy Reviews*, vol. 16, pp. 2926-2939.
- Banerjee A., Mukherjee V. and Ghoshal S.P. 2014. An opposition-based harmony search algorithm for engineering optimization problems. *Ain Shams Engineering Journal*, vol. 5, pp. 85-101
- Banerjee A., Mukherjee V. and Ghoshal S.P. 2014(a). Intelligent fuzzy-based reactive power compensation of an isolated hybrid power system. *International Journal of Electrical Power & Energy Systems*, vol. 57, pp. 164-177.
- Bhatti T.S., Al-Ademi A.A.F. and Bansal N.K. 1997. Load frequency control of isolated wind diesel hybrid power systems. *Energy Conversion and Management*, vol. 38, pp. 829-837.
- Chatterjee A., Ghoshal S.P. and Mukherjee V. 2012. Solution of combined economic and emission dispatch problems of power systems by an opposition-based harmony search algorithm. *International Journal of Electrical Power & Energy Systems*, vol. 39, pp. 9-20.
- Costa P.M., Matos M.A. and Lopes J.P. 2008. Regulation of micro generation and microgrids. *International Journal of Energy Technology and Policy*, vol. 10, pp. 3893-3904.
- Geem Z.W., Kim J.H. and Loganathan G.V. 2001. A new heuristic optimization algorithm: harmony search. *Simulations*, vol. 76, pp. 60-68.
- Goldberg D.E. 1989. Genetic Algorithms in Search, Optimization, and Machine Learning. *AddisonWesley Longman Publishing Co., USA*.
- Haiping M., Xieyong R. and Baogen J. 2010. Oppositional ant colony optimization algorithm and its application to fault monitoring. *29th Chinese Control Conference*, pp. 3895-3898.
- Kennedy J. and Eberhart R. 1995. Particle swarm optimization. *International Neural Network Society*, vol. 4, pp. 1942 – 1948.
- Omran M.G.H. and Mahdavi M. 2008. Global-best harmony search. *Applied Mathematics and Computation*, vol. 198, pp. 643-656.
- Pan Q.K., Suganthan P.N., Tasgetiren M.F. and Liang J.J.. 2010. A self-adaptive global best harmony search algorithm for continuous optimization problems. *Applied Mathematics and Computation*, vol. 216, pp. 830-848.
- Passino K.M. 2002. Biomimicry of bacteria foraging for distributed automation and control. *IEEE Control Systems Magazine*, vol. 22, pp. 52-67.
- Rahnamayan S., Tizhoosh H.R. and Salama M.M.A. 2007. Quasi oppositional differential evolution. *IEEE Congress on Evolutionary Computation*, pp. 2229-2236.
- Rahnamayan S., Tizhoosh H.R. and Salama M.M.A. 2008. Opposition versus randomness in soft computing techniques. *Applied Soft Computing*, vol. 8, pp. 906-918.
- Rashedi E., Nezamabadi-pour H. and Saryazdi S. 2009. GSA: a gravitational search algorithm. *Information Sciences*, vol. 179, pp. 2232-2248.
- Roy P.K. and Mandal D. 2011. Quasi-oppositional biogeography-based optimization for multi-objective optimal power flow. *Electric Power Components and Systems*, vol. 40, pp. 236-256.
- Roy P.K. and Mandal D. 2014. Oppositional biogeography-based optimization for optimal power flow. *International Journal of Power and Energy Conversion*, vol. 5, pp. 47-69.
- Saha S.K., Ghoshal S.P., Kar R. and Mandal D. 2013. Cat swarm optimization algorithm for optimal linear phase FIR filter design. *ISA Transactions*, vol. 52, pp. 781-794.
- Saleem A. and Lind M. 2010. Requirement analysis for autonomous systems and intelligent agents in future Danish electric power systems. *International Journal of Advanced Science and Technology*, vol.3, pp. 60-68.
- Shaw B., Mukherjee V. and Ghoshal S.P. 2012. A novel opposition-based gravitational search algorithm for combined economic and emission dispatch problems of power systems. *International Journal of Electrical Power & Energy Systems*, vol. 35, pp. 21-33.

- Shaw B., Mukherjee V. and Ghoshal S.P. 2011. Seeker optimization algorithm: application to the solution of economic load dispatch problems. *International Journal of Bio-Inspired Computation*, vol. 3, pp. 275-285.
- Storn R. and Price K. 1995. Differential Evolution – A simple and efficient adaptive scheme for global optimization over continuous spaces. *Technical Report*.
- Sun Z. and Zhang X. 2012. Advances on distributed generation technology. *Energy Procedia*, vol. 17, pp. 32-38, 2012.
- Tizhoosh H. 2005. Opposition-based learning: a new scheme for machine intelligence. *International Conference on Intelligent Agents, Web Technologies and Internet Commerce*, pp. 695-701.
- Tripathy S.C. and Mishra I.P. 1996. Dynamic performance of wind-diesel power syst. with capacitive energy storage. *Energy Conversion and Management*, vol. 37, no. 12, pp. 1787-1798.
- Tsili M. and Papathanassiou S.. 2009. A review of grid code technical requirements for wind farms. *IET Renewable Power Generation*, vol. 3, pp. 308-332.
- Zhong J. 2006. PID Controller Tuning: A Short Tutorial, *Spring*.

### Biographical notes

**Tarkeshwar** received M.Tech degree from National Institutes of Technology Hamirpur in 2012 and B.Tech degree from *Biju Patnaik University of Technology (BPUT)*, Rourkela Orissa, India. Currently, he is a research scholar in the Department of Electrical Engineering, Indian School of Mines, Dhanbad, India. His current area of research includes power system optimization, artificial intelligence and load frequency analysis.

**V. Mukherjee** was born in 1970 at Raina, Burdwan, West Bengal, India. He received his graduation in electrical engineering and post graduation in power system from B.E. College, Shibpur, Howrah, India and B.E. College (Deemed University), Shibpur, Howrah, India, respectively. He received his Ph.D. degree from NIT, Durgapur, India. Presently, he is an assistant professor in the department of electrical engineering, Indian School of Mines, Dhanbad, Jharkhand, India. His research interest is application of soft computing intelligence to various fields of power systems. He will be available at vivek\_agamani@yahoo.com. Dr. Mukherjee is a member of IEEE and The Institution of Engineers (India).

**Almoataz Y. Abdelaziz** was born in Cairo, Egypt, in 1963. He received the B. Sc. and M. Sc. degrees in electrical engineering from Ain Shams University, Cairo, Egypt in 1985, 1990 respectively and the Ph. D. degree in electrical engineering according to the channel system between Ain Shams University, Egypt and Brunel University, England in 1996. He is currently a professor of electrical power engineering in Ain Shams University. Dr. Abdelaziz has supervised a large number of Ph. D. and M. Sc. research work in his research interest areas which include the applications of artificial intelligence to power systems and protection and new optimization techniques in power systems operation and planning. He has authored or coauthored more than 120 refereed journal and conference papers. Dr. Abdelaziz is a member of the editorial board and a reviewer of technical papers in several journals and conferences. He is also a member in IEEE, IET and the Egyptian Sub-Committees of IEC and CIGRE. Dr. Abdelaziz has been awarded Ain Shams University Prize for distinct researches in 2002 and for international publishing in 2010, 2011 and 2012.

Received March 2015

Accepted July 2015

Final acceptance in revised form July 2015